

Inspection Practices for Piping System Components

API RECOMMENDED PRACTICE 574
FIFTH EDITION, FEBRUARY 2024



Special Notes

API publications necessarily address problems of a general nature. With respect to particular circumstances, local, state, and federal laws and regulations should be reviewed. The use of API publications is voluntary. In some cases, third parties or authorities having jurisdiction may choose to incorporate API standards by reference and may mandate compliance.

Neither API nor any of API's employees, subcontractors, consultants, committees, or other assignees make any warranty or representation, either express or implied, with respect to the accuracy, completeness, or usefulness of the information contained herein, or assume any liability or responsibility for any use, or the results of such use, of any information or process disclosed in this publication. Neither API nor any of API's employees, subcontractors, consultants, or other assignees represent that use of this publication would not infringe upon privately owned rights.

API publications may be used by anyone desiring to do so. Every effort has been made by the Institute to ensure the accuracy and reliability of the data contained in them; however, the Institute makes no representation, warranty, or guarantee in connection with this publication and hereby expressly disclaims any liability or responsibility for loss or damage resulting from its use or for the violation of any authorities having jurisdiction with which this publication may conflict.

API publications are published to facilitate the broad availability of proven, sound engineering and operating practices. These publications are not intended to obviate the need for applying sound engineering judgment regarding when and where these publications should be utilized. The formulation and publication of API publications is not intended in any way to inhibit anyone from using any other practices.

Any manufacturer marking equipment or materials in conformance with the marking requirements of an API standard is solely responsible for complying with all the applicable requirements of that standard. API does not represent, warrant, or guarantee that such products do in fact conform to the applicable API standard.

All rights reserved. No part of this work may be reproduced, translated, stored in a retrieval system, or transmitted by any means, electronic, mechanical, photocopying, recording, or otherwise, without prior written permission from the publisher. Contact the publisher, API Publishing Services, 200 Massachusetts Avenue, NW, Suite 1100, Washington, DC 20001.

Copyright © 2024 American Petroleum Institute

Foreword

Nothing contained in any API publication is to be construed as granting any right, by implication or otherwise, for the manufacture, sale, or use of any method, apparatus, or product covered by letters patent. Neither should anything contained in the publication be construed as insuring anyone against liability for infringement of letters patent.

The verbal forms used to express the provisions in this document are as follows.

Shall: As used in a standard, “shall” denotes a minimum requirement in order to conform to the standard.

Should: As used in a standard, “should” denotes a recommendation or that which is advised but not required in order to conform to the standard.

May: As used in a standard, “may” denotes a course of action permissible within the limits of a standard.

Can: As used in a standard, “can” denotes a statement of possibility or capability.

This document was produced under API standardization procedures that ensure appropriate notification and participation in the developmental process and is designated as an API standard. Questions concerning the interpretation of the content of this publication or comments and questions concerning the procedures under which this publication was developed should be directed in writing to the Director of Standards, American Petroleum Institute, 200 Massachusetts Avenue, NW, Suite 1100, Washington, DC 20001. Requests for permission to reproduce or translate all or any part of the material published herein should also be addressed to the director.

Generally, API standards are reviewed and revised, reaffirmed, or withdrawn at least every five years. A one-time extension of up to two years may be added to this review cycle. Status of the publication can be ascertained from the API Standards Department, telephone (202) 682-8000. A catalog of API publications and materials is published annually by API, 200 Massachusetts Avenue, NW, Suite 1100, Washington, DC 20001.

Suggested revisions are invited and should be submitted to the Standards Department, API, 200 Massachusetts Avenue, NW, Suite 1100, Washington, DC 20001, standards@api.org.

Contents

1	Scope.....	1
2	Normative References	1
3	Terms, Definitions, Acronyms, and Abbreviations	1
3.1	Terms and Definitions	1
3.2	Acronyms and Abbreviations	11
4	Introduction to Piping.....	12
4.1	Piping Components	12
4.2	Tubing	14
4.3	Valves	14
4.4	Fittings	22
4.5	Flanges.....	25
4.6	Expansion Joints	25
4.7	Piping Supports	26
4.8	Flexible Hoses	27
5	Piping Design and Construction	27
5.1	Design and Construction Standards.....	27
5.2	Methods of Construction.....	28
5.3	Materials of Construction.....	34
6	Reasons for Inspection	37
6.1	General	37
6.2	Process and Personnel Safety	37
6.3	Regulatory Requirements	37
6.4	Reliable Operation	37
7	Inspection and Monitoring Planning.....	38
7.1	Background	38
7.2	Developing an Inspection Plan	38
7.3	Monitoring Process Piping	44
7.4	Inspection Guidance for Location-specific Damage	49
7.5	Inspection Guidance for Specific Damage Mechanisms	67
7.6	Reviewing and Updating Inspection Plans (Future Content)	73
7.7	IOWs	73
7.8	Inspection of New Fabrication.....	73
7.9	Newly Commissioned Piping Inspection (Future Content)	74
8	Strategies for Establishing Frequency of Inspection.....	74
8.1	Fixed Interval	74
8.2	RBI	74
8.3	Opportunities for Inspection (Future Content)	75
8.4	On-stream Inspection	75
8.5	Offline Inspection	76
8.6	Inspection Scope	76
9	Safety Precautions and Preparatory Work.....	76
9.1	Safety Precautions.....	76
9.2	Communication	77
9.3	Preparatory Work	77
9.4	Cleaning and Surface Preparation for Inspection (Future Content).....	79
9.5	Investigation of Active Leaks	79
10	Inspection Types, Methods, and Limitations	79
10.1	External Visual Inspection	79
10.2	Internal Visual Inspection	86

10.3	Specific Areas or Components for Inspection.....	88
10.4	Thickness Measurements	93
10.5	Determination of Minimum Required Thickness	101
10.6	Other Inspection Methods/Techniques.....	105
10.7	Nonmetallic Piping.....	106
11	Inspection Results	107
11.1	Evaluation of Inspection Results	107
11.2	Determination of Follow-up Actions	109
11.3	Using Fitness-For-Service	109
12	Rerating and Repair.....	110
12.1	Rerating of Piping System	110
12.2	Repairing Pipe Damage	111
13	Pressure Tests	113
13.1	Purpose of Testing.....	113
13.2	Types of Pressure Tests (Future Content).....	113
13.3	Performing Pressure Tests	113
13.4	Pressure Testing Considerations (Future Content)	115
13.5	Pressure Test Safety Considerations	115
14	Records and Reports.....	115
14.1	General.....	115
14.2	Records.....	116
14.3	Reports (Future Content)	118
Annex A	(informative) External Inspection Checklist for Process Piping.....	119
Annex B	(informative) Tables of Pipe Schedules	120
Annex C	(informative) Statistical Analysis of Circuit Thickness Data	127
Bibliography	130

Figures

1	Cross Section of a Typical Wedge Gate Valve.....	16
2	Cross Section of a Typical Globe Valve	17
3	Cross Sections of Typical Lubricated and Nonlubricated Plug Valves	18
4	Cross Section of a Typical Ball Valve	19
5	Cross Section of a Typical Diaphragm Valve.....	19
6	Typical Butterfly Valve.....	20
7	Cross Sections of Typical Check Valves.....	21
8	Cross Section of a Typical Slide Valve	23
9	Flanged-end Fittings and Wrought Steel Butt-welded Fittings	24
10	Forged Steel Threaded and Socket-welded Fittings	25
11	Cross Section of a Socket-welded Tee Connection	29
12	Flange Facings Commonly Used in Refinery and Chemical Plant Piping	30
13	Types of Flanges.....	31
14	Cross Section of a Typical Bell-and-Spigot Joint.....	31
15	Cross Sections of Typical Packed and Sleeve Joints.....	32
16	Cross Sections of Typical Tubing Joints	33
17	Erosion of Piping	40
18	Corrosion of Piping.....	41
19	Internal Corrosion of Piping	41
20	Severe Atmospheric Corrosion of Piping.....	42
21	Piping Circuit Example	48
22	SAI Corrosion	54
23	Underground Piping Corrosion beneath Poorly Applied Tape Wrap.....	58

24	Pipe-to-Soil Internal Potential Survey Use to Identify Active Corrosion.....	59
25	Example of Pipe-to-Soil Potential Survey Chart	60
26	Wenner Four-pin Soil Resistivity Test	62
27	Soil Bar Used for Soil Resistivity Measurements.....	63
28	Two Types of Soil Boxes Used for Soil Resistivity Measurements	64
29	Case of Doubling due to Mode Converted Shear Wave Echo Occurring between the Backwall Echoes	97
30	Example of Screen Display of UT Thickness Gauge with Automatic Temperature Compensation	98
31	Radiograph of a Catalytic Reformer Line	100
32	Radiograph of Corroded Pipe Whose Internal Surface Is Coated with Iron Sulfide Scale	100
33	Sketch and Radiograph of Dead-end (Deadleg) Corrosion	101
34	Typical Isometric Sketch.....	117
35	Typical Tabulation of Thickness Data.....	118

Tables

1	API and ASME Valve Design Standards and Codes.....	15
2	Mix Point Thermal Fatigue Screening Criteria	52
3	Damage Mechanisms Associated with Nonmetallic Piping	72
4	Table 2 of API 570	86
5	Minimum Structural Thickness and Minimum Alert Thicknesses for Carbon and Low-alloy Steel Pipe	103
6	Comparison of Common Nonmetallic Piping NDE Techniques.....	108
B.1	Nominal Pipe Sizes, Schedules, Weight Classes, and Dimensions of Ferritic Steel Pipe.....	120
B.2	Nominal Pipe Sizes, Schedules, and Dimensions of Stainless Steel Pipe	124
B.3	Permissible Tolerances in Diameter and Thickness for Ferritic Pipe	126

Inspection Practices for Piping System Components

1 Scope

This recommended practice supplements API 570 by providing piping inspectors with information that can improve their skills and increase their basic knowledge of inspection practices. This recommended practice describes inspection practices for piping, tubing, valves (other than control valves), and fittings used in petroleum refineries and chemical plants. Common piping components, valve types, pipe joining methods, inspection planning processes, inspection intervals and techniques, and types of records are described to aid the inspectors in fulfilling their role in implementing API 570. This publication does not cover the inspection of specialty items, including instrumentation, furnace tubulars, and control valves.

2 Normative References

The following documents are referred to in the text in such a way that some or all their content constitutes requirements of this document. For dated references, only the edition cited applies. For undated references, the latest edition of the referenced document, including any addenda, applies.

API 570, *Piping Inspection Code: In-service Inspection, Rating, Repair, and Alteration of Piping Systems*

API Recommended Practice 571, *Damage Mechanisms Affecting Fixed Equipment in the Refining Industry*

API Recommended Practice 578, *Material Verification Program for New and Existing Assets*

API 579-1/ASME FFS-1 ¹, *Fitness-For-Service*

API Recommended Practice 580, *Elements of a Risk-based Inspection Program*

ASME B16.20, *Metallic Gaskets for Pipe Flanges*

ASME B16.25, *Buttwelding Ends*

ASME B16.34, *Valves—Flanged, Threaded, and Welding End*

ASME B31.3, *Process Piping*

ASME *Boiler and Pressure Vessel Code (BPVC), Section V: Nondestructive Examination*

ASTM G57 ², *Standard Test Method for Measurement of Soil Resistivity Using the Wenner Four-Electrode Method*

3 Terms, Definitions, Acronyms, and Abbreviations

For the purposes of this document, the following terms and definitions apply.

NOTE Definitions for terms delineated with asterisks are maintained by API 574. If another document plans to reference, see API Bulletin 590 for reference.

3.1 Terms and Definitions

3.1.1

alloy material

Any metallic material (including welding filler materials) that contains alloying elements, such as chromium, nickel, or molybdenum, which are intentionally added to enhance mechanical or physical properties and/or corrosion resistance.

¹ American Society of Mechanical Engineers, Two Park Avenue, New York, New York 10016, www.asme.org.

² ASTM International, 100 Barr Harbor Drive, West Conshohocken, Pennsylvania 19428, www.astm.org.

NOTE 1 Alloys may be ferrous or nonferrous based.

NOTE 2 For purposes of this recommended practice, carbon steels are not considered alloys.

3.1.2 alteration

A physical change in any component that has design implications affecting the pressure-containing capability of a piping system beyond the scope described in existing data reports.

NOTE The following are not considered alterations: comparable or duplicate replacement and replacements in-kind and the addition of small-bore attachments that do not require reinforcement or additional support.

3.1.3 auxiliary piping

Instrument and machinery piping, typically small-bore secondary process piping that can be isolated from primary piping systems but is normally not isolated.

NOTE Examples include flush lines, seal oil lines, analyzer lines, balance lines, buffer gas lines, drains, and vents.

3.1.4 cladding

A metal integrally bonded onto another metal under high pressure and temperature whose properties are better suited to resist damage from the process than the substrate metal.

3.1.5 condition monitoring location CML

A designated area on piping systems where periodic examinations are conducted to directly assess and monitor the condition of the piping system using a variety of examination methods and techniques based on damage mechanism susceptibility.

NOTE 1 CMLs may contain one or more examination points and can be a single small area on a piping system [e.g. a 2 in. (50 mm) diameter spot] or a plane through a section of pipe where examination points exist in all four quadrants of the plane.

NOTE 2 CMLs include, but are not limited to, what were previously called "thickness monitoring locations."

3.1.6 contact points

The locations at which a pipe or component rests on or against a support or other object, which may increase its susceptibility to external corrosion, fretting, wear, or deformation, especially because of moisture and/or solids collecting at the interface of the pipe and supporting member.

3.1.7 corrosion allowance

Additional material thickness available to allow for metal loss during the service life of the piping component.

NOTE Corrosion allowance is not used in design strength calculations.

3.1.8 corrosion rate

The rate of metal loss due to erosion, erosion-corrosion, and/or the chemical reaction(s) with the environment, either internal and/or external.

3.1.9 corrosion specialist

A person acceptable to the owner-operator who is knowledgeable and experienced in the specific process chemistries, damage mechanisms, materials selection, corrosion mitigation methods, corrosion-monitoring techniques, and their impact on piping systems.

3.1.10**corrosion under insulation****CUI**

External corrosion of piping, pressure vessel, and structural components resulting from water trapped under insulation.

NOTE External chloride stress corrosion cracking (ECSCC) of austenitic and duplex stainless steel under insulation is also classified as CUI damage.

3.1.11**critical check valves**

Check valves that need to operate reliably to avoid the potential for hazardous events or substantial consequences should reverse flow occur.

3.1.12**cyclic service**

Refers to service conditions that may result in cyclic loading and produce fatigue damage or failure (e.g. cyclic loading from pressure, thermal, and/or mechanical loads).

NOTE 1 Other cyclic loads associated with vibration may arise from such sources as impact, turbulent flow vortices, resonance in compressors, and wind, or any combination thereof.

NOTE 2 API 579-1/ASME FFS-1—Section I.A.15 has a definition of cyclic service. A screening procedure to determine if a component is in cyclic service is provided in Part 14. A definition of “severe cyclic conditions” is in ASME B31.3—Section 300.2, Definitions.

3.1.13**damage mechanism**

Any type of deterioration encountered in the refining and chemical process industry that can result in flaws/defects that can affect the integrity of equipment.

EXAMPLE Corrosion, cracking, erosion, dents, and other mechanical, physical, or chemical impacts. See API 571 for a comprehensive list and description of damage mechanisms.

3.1.14**deadlegs**

Components of a piping system that normally have little or no significant flow.

3.1.15**defect**

A discontinuity or discontinuities that by nature or accumulated effect render a part or product unable to meet minimum applicable acceptance standards or specifications (e.g. total crack length).

NOTE The term designates rejectability.

3.1.16**design pressure**

The pressure at the most severe condition of coincident internal or external pressure and temperature (minimum or maximum) expected during service.

NOTE It is the same as the design pressure defined in ASME B31.3 and other code sections and is subject to the same rules relating to allowances for variations of pressure or temperature or both.

3.1.17**design temperature**

The temperature used for the design of the piping system per the applicable construction code.

NOTE It is the same as the design temperature defined in ASME B31.3 and other code sections and is subject to the same rules relating to allowances for variations of pressure or temperature or both. Different components in the same piping system or circuit can have different design temperatures. In establishing this temperature, consideration should be given to process fluid temperatures, ambient temperatures, heating/cooling media temperatures, and insulation.

3.1.18* **doubling**

The error that can occur when an ultrasonic thickness measurement instrument displays the measured thickness value based on the second back-wall echo (i.e. double the thickness) versus the first back-wall echo.

NOTE 1 This can occur when measuring thicknesses below the minimum specified range of a transducer (probe) or when the transducer element is either worn or low in sensitivity.

NOTE 2 Doubling (or even tripling) can also occur in some cases when measuring thicknesses around 0.200" (5 mm) while using echo-to-echo mode if the signals from the second or third back-wall echo are smaller in amplitude than subsequent echoes.

3.1.19 **examination point** recording point measurement point test point

A more specific location within a CML. CMLs may contain multiple examination points, for example, a piping component may be a CML and have multiple examination points (e.g. an examination point in all four quadrants of the CML on the piping component).

NOTE The term "test point" is no longer in use because "test" refers to mechanical or physical tests (e.g. tensile tests or pressure tests).

3.1.20 **examinations**

A process by which an examiner or inspector investigates a component of the piping system using nondestructive examination (NDE) in accordance with approved NDE procedures (e.g. inspection of a CML and quality control of repair areas).

NOTE Examinations would be typically those actions conducted by NDE personnel, welding inspectors, or coating inspectors but may also be conducted by authorized piping inspectors.

3.1.21 **examiner**

A person who assists the inspector by performing specific NDE on piping system components and evaluates to the applicable acceptance criteria but does not evaluate the results of those examinations in accordance with API 570 requirements, unless specifically trained and authorized to do so by the owner-operator.

3.1.22 **external inspection**

A visual inspection performed from the outside of a piping system to find conditions that could impact the piping systems' ability to maintain pressure integrity or conditions that compromise the integrity (e.g. stanchions, pipe supports, shoes, and hangers). The external inspection may be done either while the piping is operating or while the piping is out of service and can be conducted at the same time as an on-stream inspection.

NOTE External inspections are also intended to find conditions that compromise the integrity of the coating and insulation coverings, and attachments (e.g. instrument and small branch connections).

3.1.23 **Fitness-For-Service evaluation**

A methodology whereby flaws and other deterioration/damage contained within piping systems are assessed in order to determine the integrity of the piping for continued service.

3.1.24**fitting**

A piping component usually associated with a branch connection, a change in direction, or a change in piping diameter.

NOTE Flanges are not considered fittings.

3.1.25**flammable materials**

As used in this recommended practice, includes all fluids that will support combustion.

NOTE 1 Refer to NFPA 704 for guidance on classifying fluids.

NOTE 2 Some regulatory documents include separate definitions of flammables and combustibles based on their flash point. In this document, flammable is used to describe both, and the flash point, boiling point, autoignition temperature, or other properties are used in addition to better describe the hazard.

3.1.26**flash point**

The lowest temperature at which a flammable product emits enough vapor to form an ignitable mixture in air.

NOTE 1 For example, gasoline's flash point is about -45 °F, and diesel's flash point varies from about 125 °F to 200 °F.

NOTE 2 An ignition source is required to cause ignition above the flash point but below the autoignition temperature.

3.1.27**flaw**

An imperfection in a piping system detected by NDE, which may or may not be a defect, depending upon the applied acceptance criteria.

3.1.28**general corrosion**

Corrosion distributed approximately uniform over the surface of the metal.

3.1.29**hold point**

A point in the repair or alteration process beyond which work may not proceed until the required inspection or NDE has been performed.

3.1.30**imperfection**

Flaws or other discontinuities noted during inspection or examination that may or may not exceed the applicable acceptance criteria.

3.1.31**indication**

A response or evidence resulting from the application of NDE that may be nonrelevant, flawed, or defective upon further analysis.

3.1.32**injection points**

Injection points are locations where water, steam, chemicals, or process additives are introduced into a process stream at relatively low flow/volume rates as compared to the flow/volume rate of the parent stream.

NOTE 1 Corrosion inhibitors, neutralizers, process antifoulants, desalter demulsifiers, oxygen scavengers, caustic, and water washes are most often recognized as requiring special attention in designing the point of injection. Process additives, chemicals, and water are injected into process streams to achieve specific process objectives.

NOTE 2 Injection points do not include locations where two process streams join (see 3.1.48, "mixing points").

EXAMPLE Chlorinating agents in reformers, water injection in overhead systems, polysulfide injection in catalytic cracking wet gas, antifoam injections, inhibitors, and neutralizers.

3.1.33 in-service

The life-cycle stage of a piping system that begins after initial installation (where typically initial commissioning or placing into active service follows) and ends at decommissioning.

NOTE 1 Piping systems that are idle in an operating site and piping systems not currently in operation because of a process outage are still considered in-service piping systems.

NOTE 2 Does not include piping systems that are still under construction or in transport to the site prior to being placed in service or piping systems that have been retired.

NOTE 3 Installed spare piping is also considered in-service, whereas spare piping that is not installed is not considered in-service.

3.1.34 in-service inspection

All inspection activities associated with in-service piping (after installation, but before it is decommissioned).

3.1.35 inspection

The external, internal, or on-stream evaluation (or any combination of the three) of the condition of a piping system conducted by the authorized inspector or the designee.

3.1.36 inspection code

Shortened title for API 570.

3.1.37 inspection plan

A strategy defining how and when a piece of pressure equipment and associated components will be inspected, examined, repaired, and/or maintained.

3.1.38 inspector

A shortened title for an authorized piping inspector qualified and certified in accordance with API 570.

3.1.39 integrity operating window

Established limits for process variables (parameters) that can affect the integrity of the equipment if the process operation deviates from the established limits for a predetermined length of time [includes critical, standard, and informational integrity operating windows (IOWs)].

3.1.40 intermittent service

The condition of a piping system whereby it is not in continuous operating service (i.e. it operates at regular or irregular intervals rather than continuously).

NOTE Occasional turnarounds or other infrequent maintenance outages in an otherwise continuous process service does not constitute intermittent service.

3.1.41**internal inspection**

An inspection performed on the inside surface of a piping system using visual and/or NDE techniques.

NOTE NDE on the outside of the pipe to determine the remaining thickness does not constitute an internal inspection.

3.1.42**jurisdiction**

A legally constituted governmental administration that may adopt rules relating to process piping systems.

3.1.43**level bridle**

The piping assembly associated with a level gauge attached to a vessel.

3.1.44**lining**

A nonmetallic or metallic material, installed on the interior of a pipe, whose properties are better suited to resist damage from the process than the substrate material.

3.1.45**localized corrosion**

Corrosion that is typically confined to a limited or isolated area(s) of the metal surface of a piping system.

3.1.46**minimum alert thickness**

flag thickness

A thickness greater than the required thickness that provides for early warning from which the future service life of the piping is managed through further inspection and remaining life assessment.

3.1.47**minimum required thickness**

required thickness

The minimum thickness without corrosion allowance for each component of a piping system based on the appropriate design code calculations and code allowable stress that consider internal and external pressure, temperature, mechanical, and structural loadings, including the effects of static head.

NOTE Minimum required thicknesses may be reassessed using Fitness-For-Service analysis in accordance with API 579-1/ASME FFS-1.

3.1.48**mixing point**

Mixing points are locations in a process piping system where two or more streams meet.

NOTE The difference in streams may be composition, temperature, or any other parameter that may cause deterioration and may require additional design considerations, operating limits, inspection, and/or process monitoring.

3.1.49**owner-operator**

An owner or operator of piping systems who exercises control over the operation, engineering, inspection, repair, alteration, maintenance, pressure testing, and rerating of those piping systems.

3.1.50**pipe**

A pressure-tight cylinder used to convey, distribute, mix, separate, discharge, meter, control, or snub fluid flows or to transmit a fluid pressure and that is ordinarily designated "pipe" in applicable material specifications.

NOTE 1 Materials designated as “tube” or “tubing” in the specifications are treated as a pipe when intended for pressure service external to fired heaters.

NOTE 2 See API 530 for piping internal to fired heaters.

3.1.51

pipe spool

A section of piping with a flange or other connecting fitting, such as a union, on both ends, that allows the removal of the section from the system.

3.1.52

piperack piping

Process piping that is supported by consecutive stanchions or sleepers (including straddle racks and extensions).

3.1.53

piping circuit

A subsection of piping systems that includes piping and components that are exposed to a process environment of similar corrosivity and expected damage mechanisms and is of similar design conditions and construction material, whereby the expected type and rate of damage can reasonably be expected to be the same.

NOTE 1 Complex process units or piping systems are divided into piping circuits to manage the necessary inspections, data analysis, and recordkeeping.

NOTE 2 When establishing the boundary of a particular piping circuit, it may be sized to provide a practical package for recordkeeping and performing field inspection.

3.1.54

piping engineer

One or more persons or organizations acceptable to the owner-operator who are knowledgeable and experienced in the engineering disciplines associated with evaluating mechanical and material characteristics affecting the integrity and reliability of piping components and systems.

NOTE The piping engineer, by consulting with appropriate specialists, should be regarded as a composite of all entities necessary to properly address piping design requirements.

3.1.55

piping system

An assembly of interconnected pipes that typically are subject to the same (or nearly the same) process fluid composition or operating conditions, or both.

NOTE 1 Some may refer to these as “loops,” but this designation is being supplanted by the “system” or “circuit” designation.

NOTE 2 Piping systems also include pipe-supporting elements (e.g. springs, hangers, guides, etc.) but do not include support structures, such as structural frames, vertical and horizontal beams, and foundations.

3.1.56

pressure design thickness

Minimum allowed pipe wall thickness needed to hold the design pressure at the design temperature.

NOTE 1 Pressure design thickness is determined using the rating code formula, including needed reinforcement thickness.

NOTE 2 Pressure design thickness does not include thickness for structural loads, corrosion allowance, or mill tolerances and therefore should not be used as the sole determinant of structural integrity for typical process piping.

3.1.57**primary process piping**

Process piping in normal, active service that cannot be valved off or, if it were valved off, would significantly affect unit operability.

NOTE Primary process piping typically does not include small-bore or auxiliary process piping (see also 3.1.65 “secondary process piping”).

3.1.58**process piping**

Hydrocarbon or chemical piping located at, or associated with, a refinery or manufacturing facility.

NOTE Process piping includes piperack, tank farm, and process unit piping, but excludes utility piping (e.g. steam, water, air, nitrogen, etc.).

3.1.59**quality assurance**

All planned, systematic, and preventative actions specified to determine if materials, equipment, or services will meet specified requirements so that the piping will perform satisfactorily in-service.

NOTE 1 Quality assurance plans will specify the necessary quality control activities and examinations.

NOTE 2 The contents of a quality assurance inspection management system for piping systems are outlined in API 570—Section 4.3.1.

3.1.60**quality control**

Those physical activities conducted to check conformance with specifications in accordance with the quality assurance plan.

EXAMPLE NDE techniques, hold point inspections, material verifications, checking certification documents, etc.

3.1.61**rating**

The work process of making calculations to establish pressures and temperatures appropriate for a piping system, including design pressure/temperature, maximum allowable working pressure (MAWP), structural minimums, required thicknesses, etc.

3.1.62**repair**

The work necessary to restore a piping system to a condition suitable for safe operation at the design conditions.

NOTE 1 Any welding, cutting, or grinding operation on a pressure-containing piping component not specifically considered an alteration is considered a repair.

NOTE 2 Repairs can be temporary or permanent.

3.1.63**rerating**

A change in either the design temperature rating, design pressure rating, or the MAWP of a piping system.

NOTE A rerating may consist of an increase, decrease, or a combination. Derating below original design conditions is a permissible way to provide additional corrosion allowance.

3.1.64**risk-based inspection****RBI**

A risk assessment and management process that considers both the probability of failure and the consequence of failure due to material deterioration.

3.1.65**secondary process piping**

Process piping located downstream of a block valve that can be valved off without significantly affecting the process unit.

NOTE Often, secondary process piping is small-bore piping (SBP).

3.1.66**small-bore piping****SBP**

Pipe or pipe components that are less than or equal to NPS 2.

3.1.67**soil-to-air interface****SAI**

An area in which external corrosion may occur or be accelerated on partially buried pipe or buried pipe where it egresses from the soil.

NOTE 1 The zone of the corrosion will vary depending on factors such as the moisture and oxygen content of the soil and operating temperature. The zone generally is from 12 in. (30 cm) below to 6 in. (15 cm) above the soil surface.

NOTE 2 Pipe running parallel with the soil surface that contacts the soil is included.

3.1.68**structural minimum thickness**

Minimum required thickness without corrosion allowance based on the mechanical loads other than pressure that result in longitudinal stress.

NOTE The thickness is either determined from a standard chart or engineering calculations. It does not include thickness for corrosion allowance or mill tolerances.

3.1.69**tell-tale holes*****sentinel holes**

Small pilot holes drilled in the pipe or component wall using specified and controlled patterns and depths to act as an early detection and safeguard against ruptures resulting from internal corrosion, erosion, and erosion-corrosion.

3.1.70**temporary repairs**

Repairs made to piping systems in order to restore sufficient integrity to continue safe operation until permanent repairs are conducted.

3.1.71**testing**

Within this document, testing generally refers to either pressure testing, whether performed hydrostatically, pneumatically or a combination hydrostatic/pneumatic, or mechanical testing to determine data such as material hardness, strength, and notch toughness.

NOTE Testing does not refer to NDE using techniques such as liquid penetrant (PT), magnetic particle (MT), etc.

3.1.72**utility piping**

Non-process piping associated with a process unit (e.g. steam, air, water, and nitrogen).

3.1.73**weld overlay**

The use of weld metal of a composition different than the base metal to provide corrosion and/or erosion resistance to the base metal.

NOTE The filler metal typically has better corrosion and/or erosion resistance to the environment than the underlying metal.

3.2 Acronyms and Abbreviations

For the purposes of this document, the following acronyms and abbreviations apply.

ACFM	alternating current field measurement
AE	acoustic emission examination technique
CML	condition monitoring location
CSCC	chloride stress corrosion cracking
CUI	corrosion under insulation
DN	diameter nominal (used in SI system to describe pipe size)
ECSCC	external chloride stress corrosion cracking
EMAT	electromagnetic acoustic transducer
ET	eddy current technique
FCC	fluid catalytic cracking
FRP	fiber-reinforced plastic
GRP	glass-reinforced plastic
HF	hydrofluoric
	NOTE Generally referred to as HF acid.
ID	inside diameter
IDMS	Inspection Data Management System
ILI	in-line inspection
IOW	integrity operating window
IP	initial pulse
MAWP	maximum allowable working pressure

MOC	management of change
MT	magnetic particle examination technique
MW	microwave examination technique
NDE	nondestructive examination
NPS	nominal pipe size

NOTE The term is typically followed, when appropriate, by the specific size designation number without an inch symbol.

EXAMPLE NPS 24 refers to a nominal pipe size of 24 in.

OD	outside diameter
P&ID	pipng and instrument diagram
PFD	process flow diagram
PMI	positive material identification
PPE	personal protective equipment
PT	liquid penetrant examination technique
PWHT	postweld heat treatment
RBI	risk-based inspection
RT	radiographic examination (method) or radiography
SAI	soil-to-air interface
SBP	small-bore piping
SCC	stress corrosion cracking
UT	ultrasonic examination technique
UV	ultraviolet

4 Introduction to Piping

4.1 Piping Components

4.1.1 Pipe

Steel and alloy pipe diameter is expressed as nominal pipe sizes (NPSs) and are manufactured to standard dimensions in NPSs up to 48 in. (1219 mm). The size refers to the approximate inside diameter (ID) of standard weight pipe for NPSs equal to or less than 12 in. (305 mm). For NPS equal to or greater than 14 in. (356 mm), the size denotes the actual outside diameter (OD).

Pipe wall thicknesses are designated as pipe schedules in NPSs up to 36 in. (914 mm); refer to Annex B. The traditional thickness designations—standard weight, extra strong, and double extra strong—differ from schedules and are used for NPSs up to 48 in. (1219 mm). In all standard sizes, the OD remains nearly constant regardless of the thickness. Table B.1 and Table B.2 list the dimensions of ferritic and stainless steel pipe from NPS $\frac{1}{8}$ [DN (diameter nominal) 6] up through NPS 24 (DN 600). See ASME B36.10M for the dimensions of welded and seamless wrought steel piping and ASME B36.19 for the dimensions of stainless steel piping.

Allowable tolerances in pipe diameter differ from one piping material to another. Table B.3 lists the acceptable tolerances for diameter and thickness of most ASTM ferritic pipe standards. The actual thickness of seamless piping can vary from its nominal thickness by a manufacturing tolerance of as much as 12.5 %. The under tolerance for welded piping is 0.01 in. (0.25 mm). Cast piping has a thickness tolerance of $+1/16$ in. (1.6 mm) and -0 in. (0 mm), as specified in ASTM A53/A53M. Consult the ASTM or the equivalent ASME material specification to determine what tolerances are permitted for a specific material.

Piping that has ends that are beveled or threaded with standard pipe threads can be obtained in various lengths. Piping can be obtained in different strength levels depending on the grades of material, including alloying material and the heat treatments specified.

Cast iron piping is generally used for nonhazardous services, such as water; it is generally not recommended for pressurized hydrocarbon service because of its brittle nature. The standards and sizes for cast iron piping differ from those for welded and seamless piping.

4.1.2 SBP, Secondary Piping, and Auxiliary Piping

SBP can be used as primary process piping, secondary piping, auxiliary piping, and for vents/drains. SBP vent/drain valves are normally connected to nipples 6 in. (152 mm) or less in length and are most often used to vent piping high points, drain piping low points, and provide a connection point for secondary/auxiliary piping. Secondary piping is normally isolated from the main process lines by closed valves and can be used for such functions as sample taps. Auxiliary piping is normally open to service but can be isolated from the primary process. Examples include flush lines, instrument piping, analyzer piping, lubrication, and seal oil piping for rotating equipment.

Inspectors and piping engineers should be aware of design, maintenance, and operating issues that cause SBP failures and may require mitigation. Those issues include, but are not limited to, the following:

- mismatched union connections from differing manufacturers;
- the potential for thermal growth or contraction that could cause SBP stresses that may lead to failure;
- cyclic loading from thermal or mechanical loads that could cause fatigue cracking (e.g. overhung SBP piping systems, the potential for PRV chattering in certain relief scenarios, flow-induced vibration, vaporization, and cavitation);
- inadequate management of change (MOC) consideration that may cause unanticipated thermal, mechanical, or corrosive scenarios on SBP;
- inadequate design (e.g. support and pipe schedule) for the various unanticipated transient loads imposed on SBP;
- inadequate protection from external impacts (e.g. vehicular traffic and maintenance activities);
- inadequate protection or support for SBP that could be subject to being used as personnel or tool/equipment support (e.g. step, tie-off, handrail, pulley, and lever);

- improperly selected components for the class of service;
- inadequate consideration for the use of socket weld versus threaded fittings, both of which can lead to premature failure if not specified and/or installed properly;
- inadequate thickness for threaded SBP after accounting for the loss of thickness from thread cutting or lack of bottom gap when welding socket welded fittings;
- not including alloy SBP in positive material identification (PMI) procedures;
- not including SBP in piping damage mechanism reviews;
- replacement of SBP components with different alloys without adequate consideration for potential new damage mechanisms (e.g. “upgrading” to stainless steel in a wet chloride environment).

Additional guidance on SBP may be found in API 570—Section 6.6.

4.2 Tubing

Tubing is similar to piping in that it is used to convey fluid and is manufactured in many ODs and wall thicknesses. Tubing is generally seamless but can be welded. Its stated size is typically the actual OD rather than NPS. [ASTM B88 tubing, which is often used for steam tracing, is an exception in that its size designation is $\frac{1}{8}$ in. (3.2 mm) less than the actual OD.] Methods used to join tubing sections include flared, flareless, and compression-type tube fittings instead of typical piping joints, such as threads, flanges, or welding. Tubing is usually made in small diameters and is often used for instrument connections, lubricating oil services, steam tracing, and similar services. Generally, tubing is more flexible than piping that allows it to be bent to desired shapes and configurations, as opposed to piping that relies much more frequently on elbows and other fittings for directional changes and is less often bent. When used for heat exchange applications, such as heaters, boilers, or other heat exchangers, the tubular component is commonly referred to as a tube rather than as tubing.

Inspectors and piping engineers should be aware of design, maintenance, and operating issues that cause tubing failures and may require mitigation. Those issues include, but are not limited to, the following:

- a) inadequate protection from external impacts (e.g. vehicular traffic and maintenance activities);
- b) improperly selected components for the class of service;
- c) improper assembly of tubing joints;
- d) cyclic loading, vibration, shock, and thermal expansion and contraction;
- e) longitudinal defects from forming;
- f) chloride stress corrosion cracking (CSCC) of stainless steel tubing, particularly at tubing supports in elevated temperatures or offshore environments;
- g) inadequate support structure for tubing.

4.3 Valves

4.3.1 General

The basic types of valves are gate, globe, plug, ball, diaphragm, butterfly, check, and slide valves. Valves are made in standard pipe sizes, materials, body thickness, and pressure ratings. Body thicknesses,

pressure ratings and other design data are provided in the applicable standards as shown in Table 1. Valve bodies can be cast, forged, machined from bar stock, or fabricated by welding a combination of two or more materials. The seating surfaces in the body can be integral with the body, or they can be made as inserts. The insert material can be the same as or different from the body material. When special nonmetallic material that could fail in a fire is used to prevent seat leakage, metal-to-metal backup seating surfaces can be provided (see API 607). Other parts of the valve trim can be made of any suitable material and can be cast, formed, forged, or machined from commercially rolled shapes. Valve ends can be flanged, threaded for threaded connections, recessed for socket welding, or beveled for butt welding. Although many valves are manually operated, they can be equipped with electric motors and gear operators or other power operators to accommodate a large size or inaccessible location or to permit actuation by instruments. Refer to API 615 for a complete overview of valve designs and reference standards.

Table 1—API and ASME Valve Design Standards and Codes

Valve Design Standard	Applicable Valve Type
API 594	Check valves
API 599	Metal plug valves
API 600	Steel gate valves
API 602	Gate, globe, and check valves
API 603	Corrosion-resistant, bolted bonnet gate valves
API 607	Fire test for quarter-turn valves and valves equipped with nonmetallic seats
API 608	Metal ball valves
API 609	Butterfly valves
ASME B16.34	Valves: flanged, threaded, and welding end

4.3.2 Gate Valves

A gate valve consists of a body that contains a gate that interrupts the process flow. This type of valve is normally used in a fully open or fully closed position and as such is often called a “block valve,” since it is not generally designed for regulating fluid flow. Gate valves larger than 2 in. (51 mm) usually have port openings that are approximately the same size as the valve end openings—this type of valve is called a “full-ported valve.” Figure 1 shows a cross section of a full-ported wedge gate valve.

Reduced port gate valves are also very common and have port openings that are smaller than the end openings. Reduced port valves should not be used as block valves associated with pressure-relief devices or in erosive applications, such as slurries, or lines that are to be “pigged.”

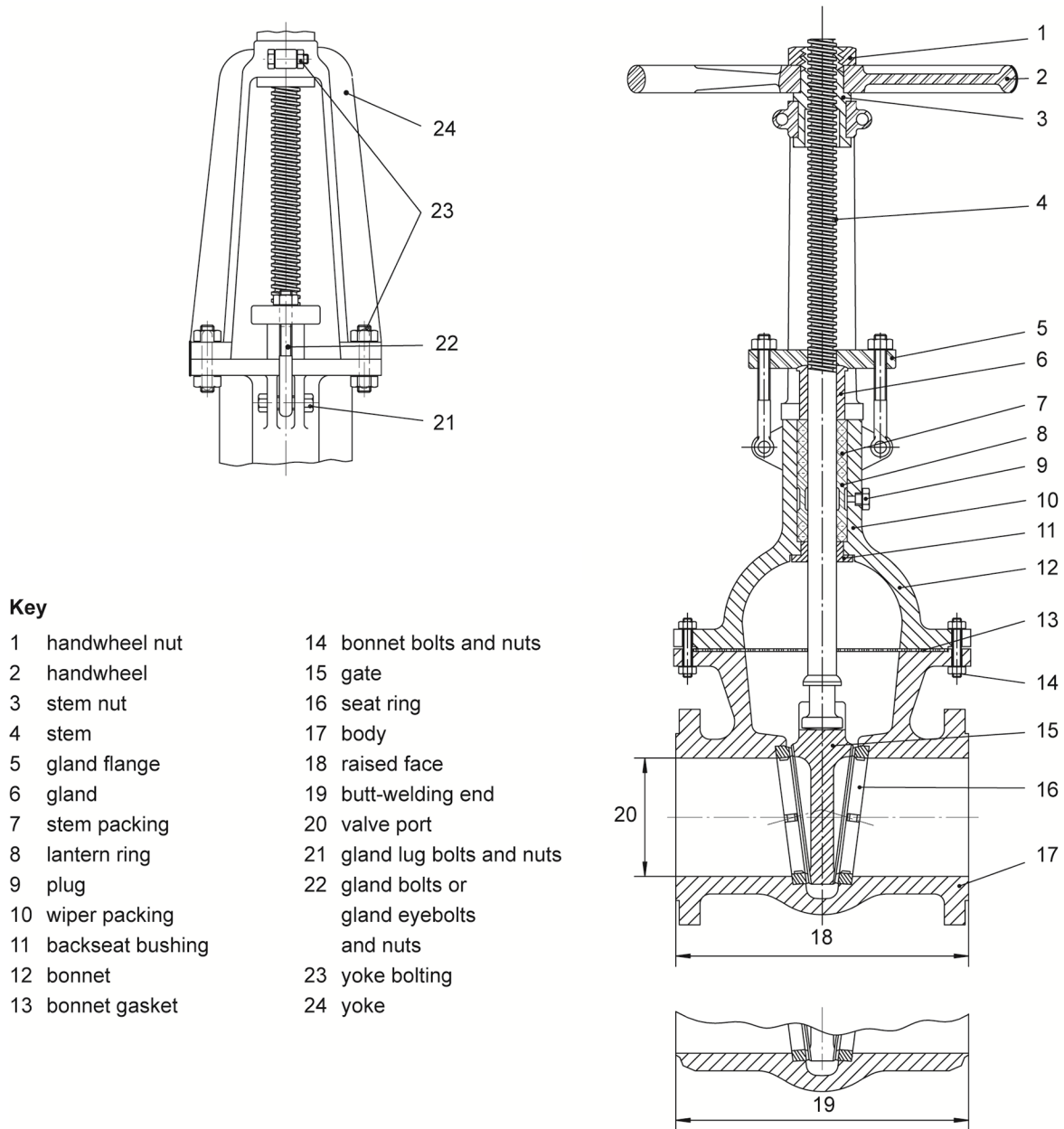

Figure 1—Cross Section of a Typical Wedge Gate Valve

4.3.3 Globe Valves

A globe valve, which is commonly used to regulate fluid flow, consists of a valve body that contains a circular disc that moves parallel to the disc axis and contacts the seat. The stream flows upward generally, except for vacuum service or when required by system design (e.g. fail closed), through the seat area against the disc, and then changes direction to flow through the body to the outlet disc. The seating surface can be flat or tapered. For fine-throttling service, a very steep tapered seat can be used; this particular type of globe valve is referred to as a needle valve. A globe valve is commonly constructed with its inlet and outlet in line and with its port opening at right angles to the inlet and outlet. Figure 2 illustrates a cross section of a globe valve.

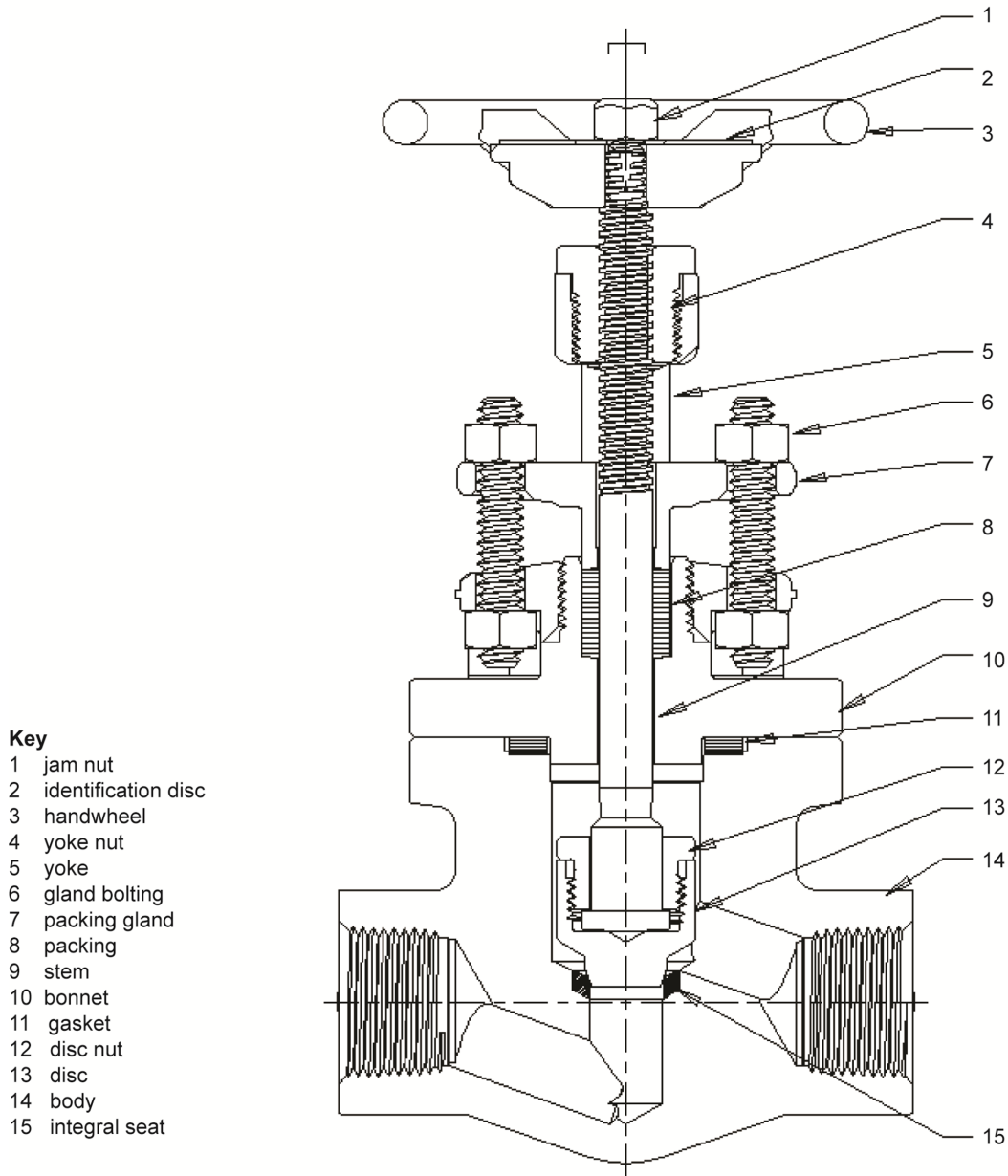

Figure 2—Cross Section of a Typical Globe Valve

4.3.4 Plug Valves

A plug valve consists of a tapered or cylindrical plug fitted snugly into a correspondingly shaped seat in the valve body. Plug valves usually function as block valves to close off flow. When the valve is open, an opening in the plug is in line with the flow openings in the valve body. The valve is closed by turning the plug one-quarter turn so that its opening is at right angles to the openings in the valve body. Plug valves can be operated by a gear-operated device or by turning a wrench on the stem. Plug valves are either lubricated or nonlubricated; Figure 3 illustrates both types. Lubricated plug valves use a grease-like lubricant that is pumped into the valve through grooves in the body and plug surfaces to provide sealing for the valve and promote ease of operation. On the other hand, nonlubricated plug valves may use metal seats or nonmetallic sleeves, seats, or complete or partial linings or coatings.

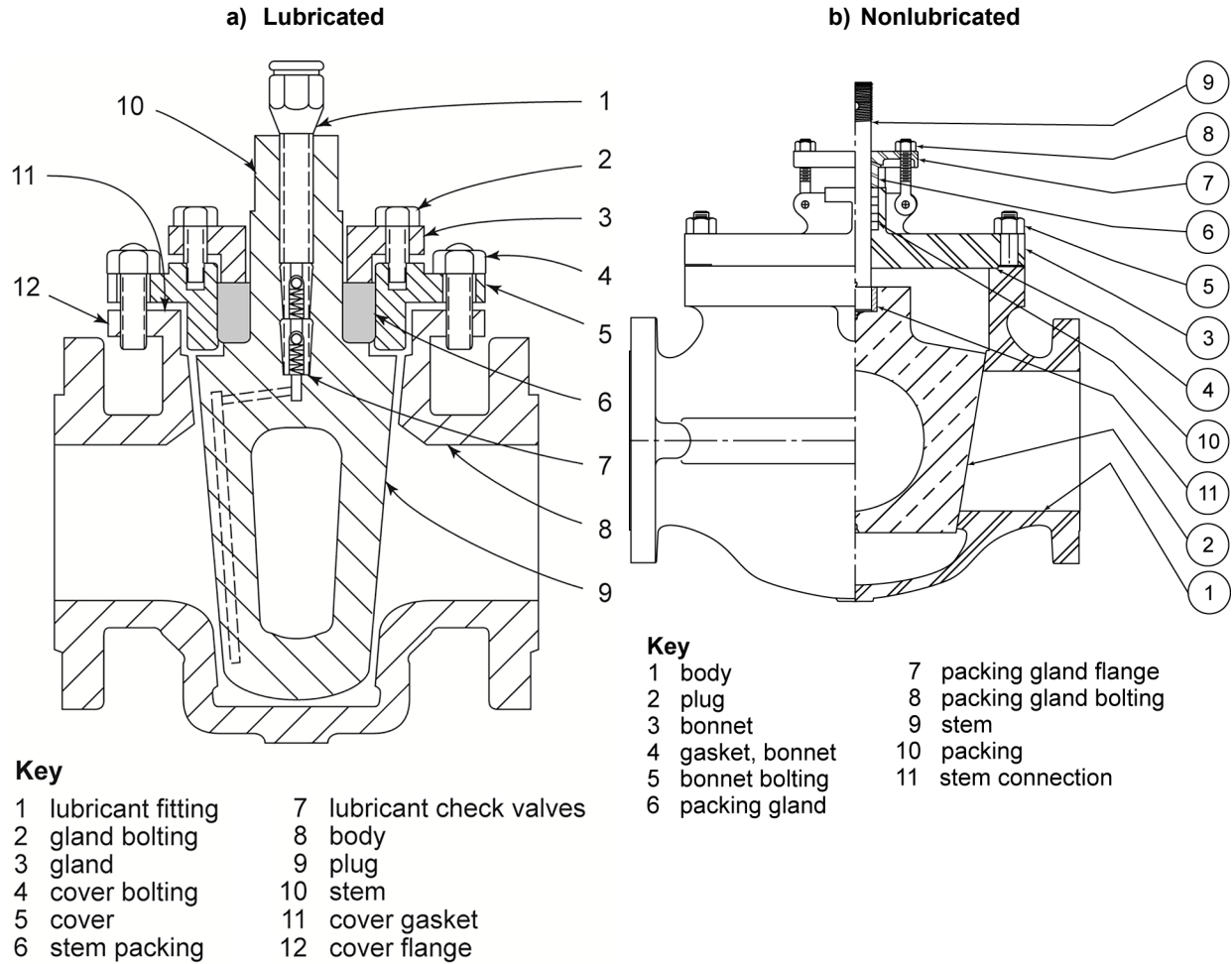

Figure 3—Cross Sections of Typical Lubricated and Nonlubricated Plug Valves

4.3.5 Ball Valves

A ball valve is another one-quarter turn valve like a plug valve except that the plug in a ball valve is spherical instead of tapered or cylindrical. Ball valves usually function as block valves to close off flow. They are well suited for conditions that require quick on/off or bubble-tight service. A ball valve is typically equipped with an elastomeric seating material that provides good shutoff characteristics; however, all-metal, high-pressure ball valves are available. Figure 4 illustrates a ball valve.

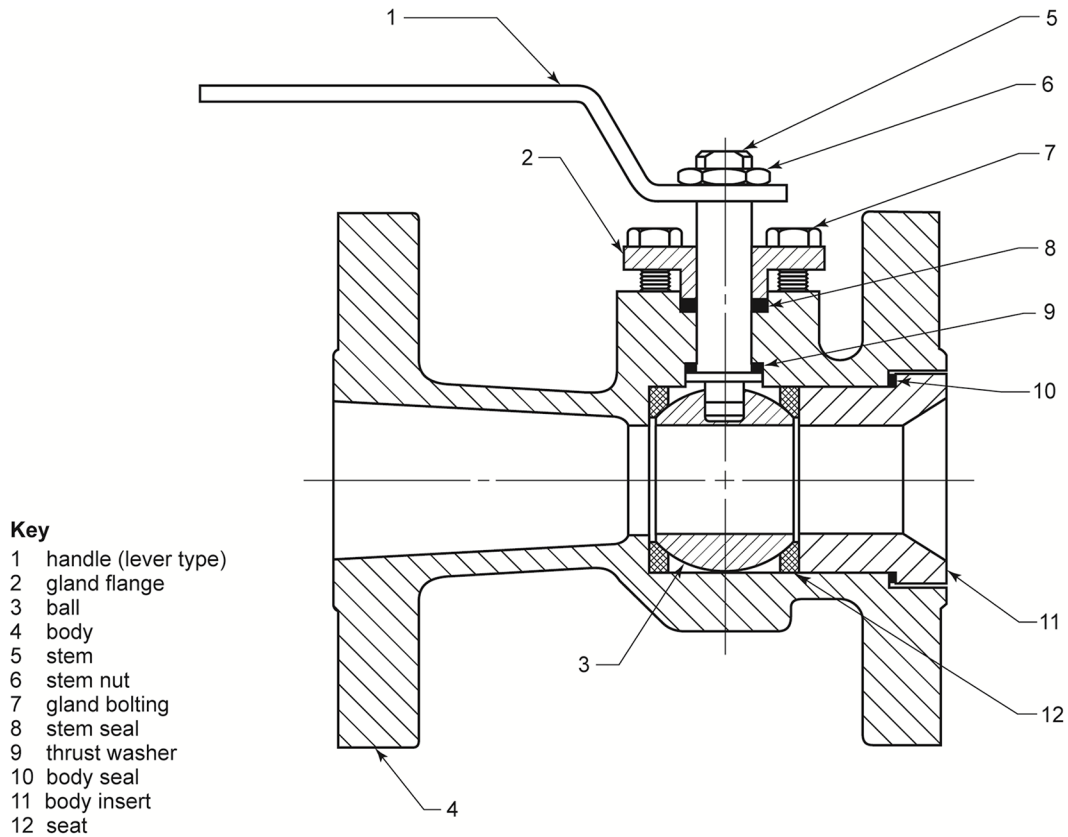

Figure 4—Cross Section of a Typical Ball Valve

4.3.6 Diaphragm Valves

A diaphragm valve is a packless valve that contains a diaphragm made of a flexible material that functions as both a closure and a seal. When the valve spindle is screwed down, it forces the flexible diaphragm against a seat, or dam, in the valve body and blocks the flow of fluid. These valves are not used extensively in the petrochemical industry, but they do have application in corrosive services below approximately 250 °F (121 °C), where a leak-tight valve is needed. Figure 5 illustrates a diaphragm valve.

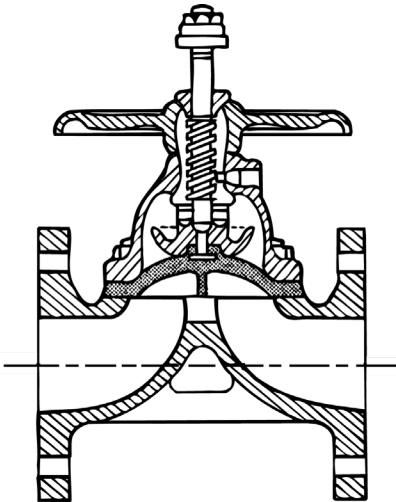

Figure 5—Cross Section of a Typical Diaphragm Valve

4.3.7 Butterfly Valves

A butterfly valve consists of a disc mounted on a stem in the flow path within the valve body. The body is usually flanged and of the lug or wafer type. A one-quarter turn of the stem changes the valve from fully closed to completely open. Butterfly valves are most often used in low-pressure service for coarse flow control. They are available in a variety of seating materials and configurations for tight shutoff in low- and high-pressure services. Large butterfly valves are generally mechanically operated. The mechanical feature is intended to prevent them from slamming shut in service. Figure 6 illustrates the type of butterfly valve usually specified for water service.

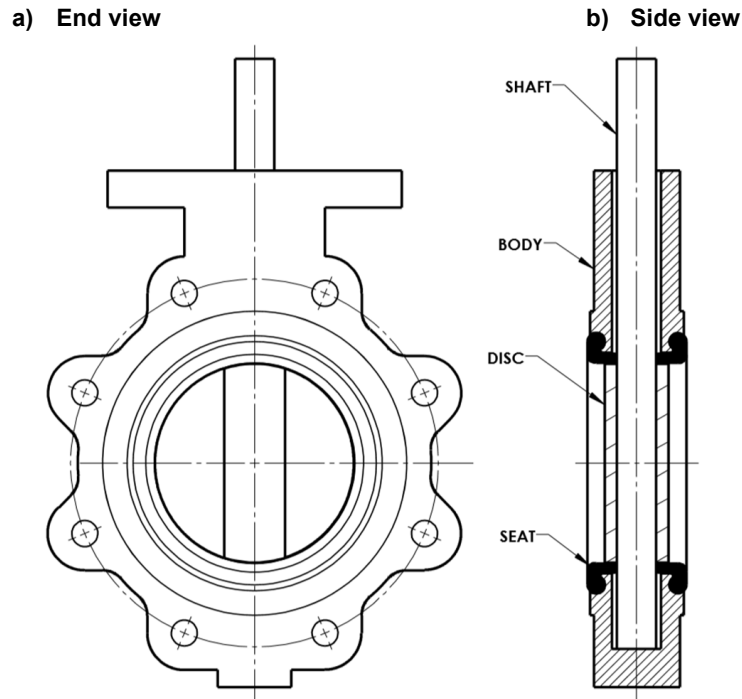
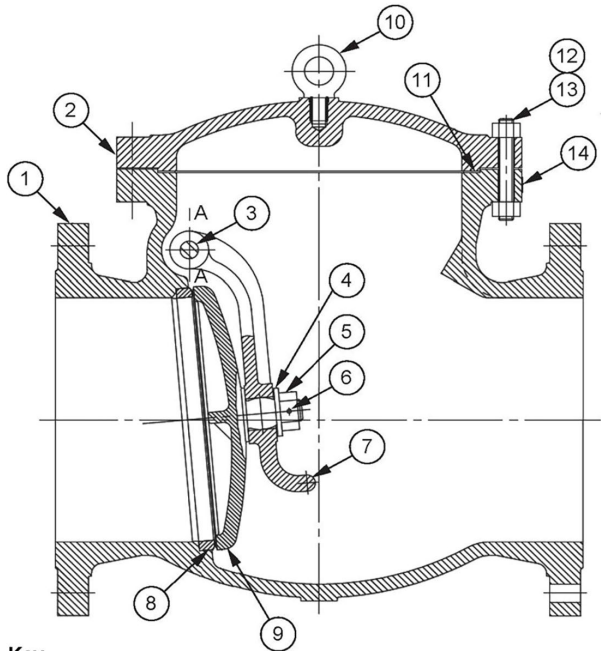

Figure 6—Typical Butterfly Valve

4.3.8 Check Valves

A check valve is used to automatically prevent backflow. The most common types of check valves are swing, lift-piston, ball, axial flow, and spring-loaded wafer check valves. Figure 7 illustrates cross sections of each type of valve; these views portray typical methods of preventing backflow.



Key

1 body	8 seat
2 bonnet	9 disc
3 hinge pin	10 eye bolt
4 disk washer	11 gasket
5 disc nut retainer	12 cover stud
6 spring cotter	13 cover nut
7 arm	14 name plate

a) Swing check

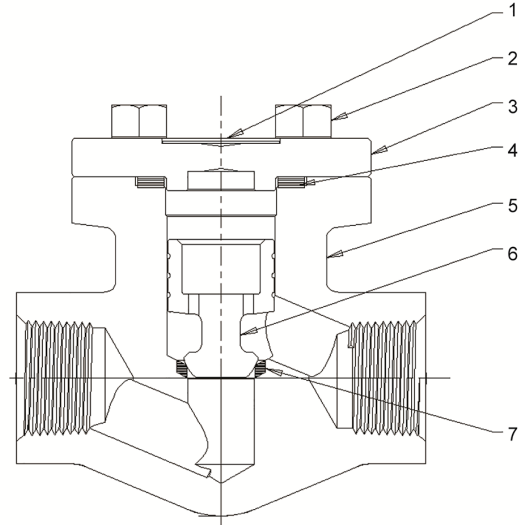

Key

1 identification disc
2 bonnet bolting
3 bonnet
4 gasket
5 body
6 disc check
7 integral seat

b) Piston check

Key

1 identification disc
2 bonnet bolting
3 bonnet
4 gasket
5 body
6 ball guide
7 ball check
8 integral seat

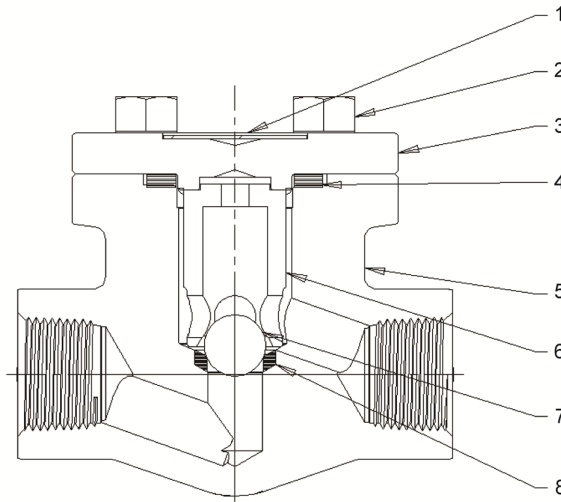

c) Ball check

Figure 7—Cross Sections of Typical Check Valves

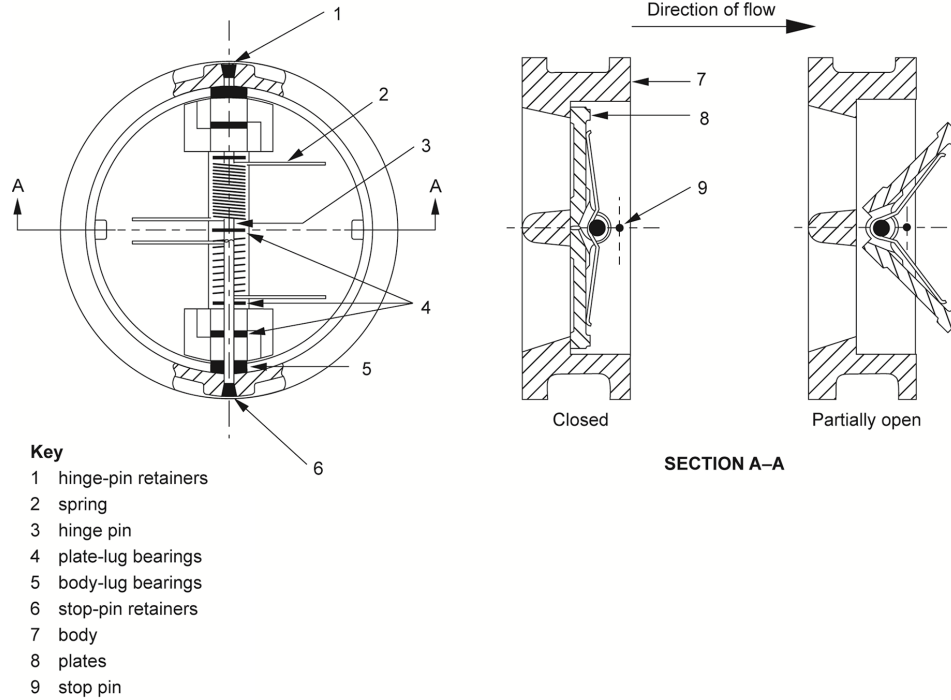

d) Dual plate

Figure 7—Cross Sections of Typical Check Valves (*continued*)

4.3.9 Slide Valves

The slide valve is a specialized gate valve generally used in erosive or high-temperature service. It consists of a flat plate that slides against a seat. The slide valve uses a fixed orifice and one or two solid slides that move in guides, creating a variable orifice that make the valve suitable for throttling or blocking. Slide valves do not make a gas-tight shutoff. One popular application of this type of valve is controlling fluidized catalyst flow in fluid catalytic cracking (FCC) units. Internal surfaces of these valves that are exposed to high wear from the catalyst are normally covered with erosion-resistant refractory. Figure 8 illustrates a slide valve.

4.4 Fittings

4.4.1 Metallic Fittings

Fittings are used to connect pipe sections and change the direction of flow or allow the flow to be diverted or added to. Fittings can be cast, forged, drawn from seamless or welded pipe, or formed and welded. Fittings can be obtained with their ends flanged, recessed for socket welding, beveled for butt welding, or threaded for threaded connections. Fittings are made in many shapes, such as wyes, tees, elbows, crosses, laterals, and reducers. Figure 9 illustrates types of flanged and butt-welded fittings. Figure 10 illustrates types of threaded and socket-welded fittings.

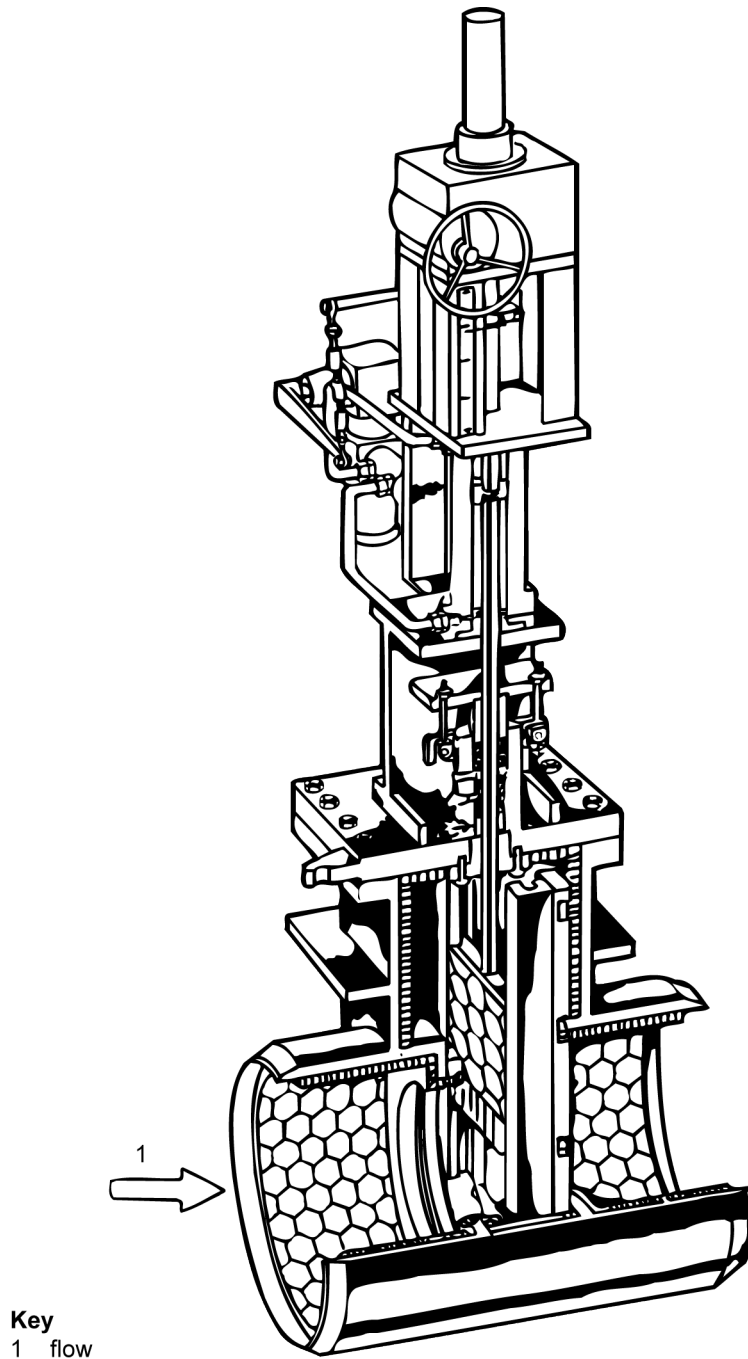
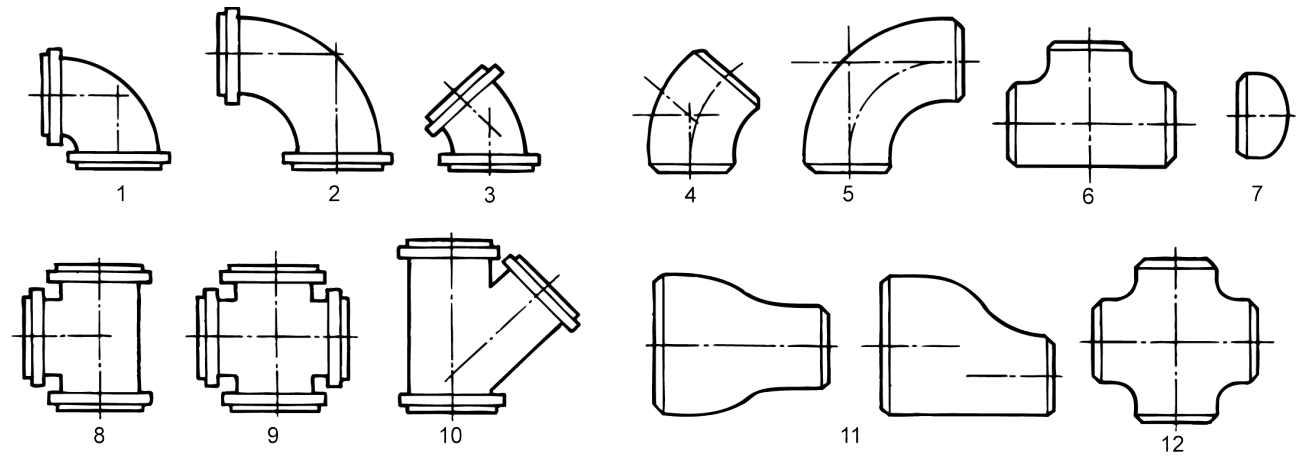

Figure 8—Cross Section of a Typical Slide Valve

4.4.2 Fiber-reinforced Plastic Fittings

Fiber-reinforced plastic (FRP) fittings are manufactured by different processes. Injection molding, filament winding, and contact molding are the most common techniques. The same criteria used to accept the pipe should be applied to fittings. Contact molded fittings should be inspected to ensure that they are manufactured to the same specification as the pipe. Contact molded fittings fabrication is critical because the layers of reinforcement must be overlapped to make sure that the strength of the layers is not compromised. One-piece contact molded fittings are the preferred method, but many items, such as tees

and branch connections, are often manufactured using two pieces of pipe. The inspector must check to make sure that the reinforcement on those pieces and the gap between them is within the tolerance specified. The exposed cut edges must be protected accordingly.



a) Flanged-end Fittings

b) Wrought Steel Butt-welded Fittings

Key

1 elbow	7 cap
2 long-radius elbow	8 tee
3 45° elbow	9 cross
4 45° elbow	10 45° lateral (wye)
5 long-radius elbow	11 reducers
6 tee	12 cross

Figure 9—Flanged-end Fittings and Wrought Steel Butt-welded Fittings

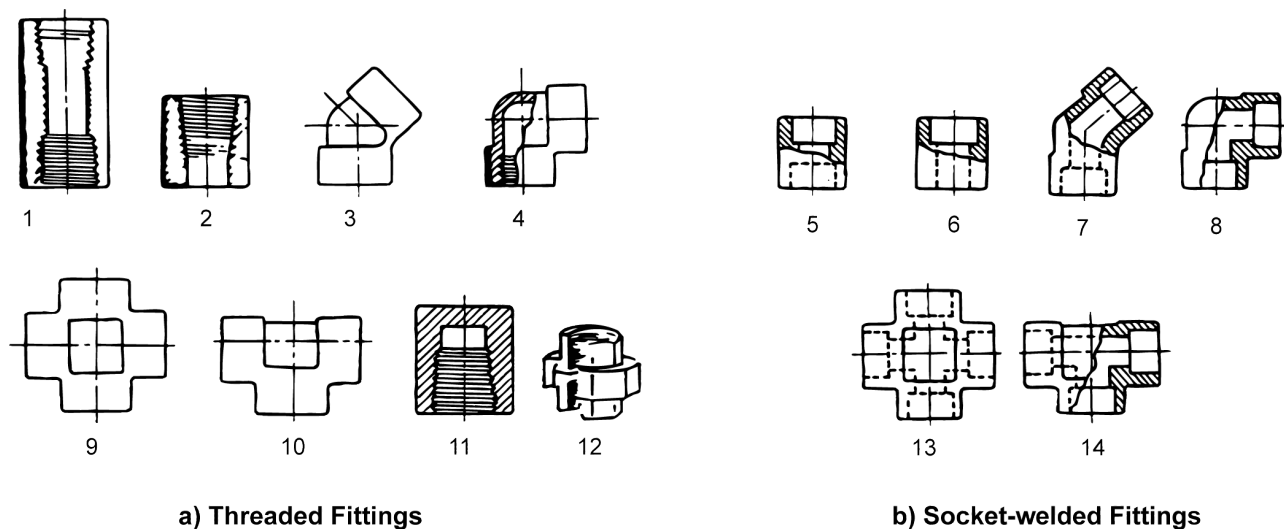
**Key**

1 coupling	8 90° elbow
2 half-coupling	9 cross
3 45° elbow	10 tee
4 90° elbow	11 cap
5 coupling	12 union
6 half-coupling	13 cross
7 45° elbow	14 tee

Figure 10—Forged Steel Threaded and Socket-welded Fittings

4.5 Flanges

4.5.1 Metallic Flanges

ASME B16.5 covers flanges of various materials through an NPS of 24 in. (610 mm). ASME B16.47 covers steel flanges that range from NPS 26 through NPS 60. The flanges of cast fittings or valves are usually integral with the fitting or the valve body.

4.5.2 FRP Flanges

FRP flanges are manufactured using the same methods as the fittings. Contact molded flanges should be inspected for dimensions, drawback, and face flatness. The layers of reinforcement should extend onto the pipe to create the proper bond and hub reinforcement. More information on FRP flanges can be found in MTI Project 160-04. FRP flanges should have the proper torques and gaskets.

4.6 Expansion Joints

Expansion joints are devices used to absorb dimensional changes in piping systems, such as those caused by thermal expansion, to prevent excessive stresses/strains from being transmitted to other piping components, and connections to pressure vessels and rotating equipment. While there are several designs, those commonly found in a plant are metallic bellows and fabric joint designs. Metallic bellows can be single-wall or multilayered, containing convolutions to provide flexibility. Often, these joints will have other design features, such as guides, to limit the motion of the joint or the type of loading applied to the joint. Metallic bellows expansion joints can be used in higher-temperature services than nonmetallic joints.

All expansion joints have specific design limits for allowable movement (axial, angular, and offset), as well as pressure and temperature design limits. These limits should be understood and not exceeded. An expansion joint may limit the pressure/temperature rating of a piping system well below the pressure/temperature rating of the piping itself. Fabric joints are often used in flue gas services at low pressure and where temperatures do not exceed the rating of the fabric material.

4.7 Piping Supports

4.7.1 General

There are many different pipe support designs, types, and styles. They include hanger type, support shoes, saddles, bearing surfaces (e.g. structural members, concrete plinth blocks, etc.), spring type, dummy legs (trunnions), slide plates, sway braces/snubbers/struts, stands, sleeves, rollers, straps, clamps, and restrictive guides or anchors.

An understanding of the function and design of pipe supports is required to manage both their integrity and the integrity of piping systems. Pipe supports can be subject to various damage mechanisms (see 7.4.6) and significant stresses from static loading and thermal movements that can affect the pipe support itself, as well as the supported piping and piping components.

4.7.2 Piping Support Design—General Considerations

Piping supports usually are designed to carry the weight of piping including valves, insulation, and the weight of the fluid contained in the pipe, including hydrostatic test conditions. Properly designed piping supports will ensure that:

- a) pipes and piping components are not subjected to unacceptable stresses from sustained loads, external loads, or vibration;
- b) the piping does not impose an unacceptable load on the connections to the equipment it services (e.g. pressure vessels, pumps, turbines, and tanks);
- c) thermal movement is controlled within allowable displacements so as not to interfere with adjacent piping or equipment and be maintained within allowable stress levels;
- d) the potential for corrosion, cracking, and other in-service damage is minimized.

4.7.3 Piping Support Design—Specific Considerations

Pipe support design considerations can differ depending on the support type or style. While some pipe support manufacturers offer innovative and proprietary designs to eliminate or minimize some of the credible damage mechanisms, the following is a list of some special piping support design parameters to take into consideration.

- a) **Pipe Shoes**—It is important that the shoe is long enough and/or guides or stops are provided on the structural steel to prevent the shoe from coming off the support, which could cause tearing or other damage to the pipe. Also, some pipe shoes may trap water between the pipe and shoe (e.g. clamp-on, bolt-on, saddles that have been stitch welded, etc.) and make inspection difficult to determine the condition of the pipe.
- b) **Pipe Sleeves**—Pipe sleeves are often used where pipe passes through a wall, under a roadway, or through an earthen berm. When used, design precautions should be taken to prevent corrosion on both the pipe and the pipe sleeve. Centering devices should also be considered to keep the inner pipe centered and prevent coating damage and corrosion. Fully welded and/or sealed sleeves may be considered if loss of containment detection and control are necessary. It should be noted that sleeves can make future pipe inspections and examinations more difficult.

- c) **Doubler Plates, Half Soles, and Wear Pads**—Additional plates may be attached to a pipe system at points where the pipe rests on bearing surfaces. Plates should be fully welded to avoid crevice corrosion except in hydrogen-charging environments, where a weep hole should be included that will not lead to moisture ingress. The use of adhesive-bonded stainless steel or composite half soles may be considered, but it is very important to make sure that the adhesive is fully bonded and maintained to effectively eliminate water entrapment. Galvanic corrosion should also be considered when using dissimilar materials for this purpose.
- d) **Dummy Legs (Trunnions)**—Historically, dummy leg (trunnion) supports were simple open-ended lengths of pipe welded to a piping system from which the piping system was supported. An open-ended design can allow moisture and debris to become trapped inside the support and cause corrosion of the support and the pipe. Dummy leg design should include, as a minimum, drain holes no smaller than $\frac{1}{4}$ in. (6 mm) located at a low point, with the unattached end of the support being fitted with a fully welded cap or end plate to prevent debris or animals from entering. Trunnion design can be improved by using solid sections, such as “C” channels or “I/H” beams, to reduce the risk of this problem. However, even solid member sections can trap water and debris depending upon their design and orientation. Incorporating a fully welded doubler pad to the pipe at the trunnion attachment location can provide additional corrosion protection and may help distribute loads more evenly. The end of a dummy leg support that is not attached to the pipe may or may not be anchored or restrained.
- e) **Supports on Insulated Lines**—Special attention is necessary for the design of supports on insulated lines to minimize the possibility of water ingress and wicking of water into the insulation.
- f) **Accessibility**—The accessibility, and therefore inspectability/maintainability, of pipe supports should be considered during design.
- g) **Welding**—Paths for water ingress into hollow supports can be minimized with the use of fully welded seams. Avoid welding undercut or excessive penetration. Welding defects associated with supports can contribute to loss of containment events and, in some cases, be of sufficiently small size to make leak detection and source identification difficult. In hydrogen-charging environments, a weep hole should be provided to avoid the buildup of pressure between the plate and pipe.
- h) **Anchors and Restraints**—A connection of a pipe to a stationary structure or foundation to restrict the movement of the pipe in one or more directions (X, Y and/or Z plane). The attachment of an anchor or restraint to a pipe should preferably encircle the pipe to distribute the stresses evenly about the circumference of the piping component(s).

4.8 Flexible Hoses

Flexible hoses are often temporarily used to transfer hydrocarbons and other process fluids to facilitate turnaround activities (clearing equipment, deinventorying, purging, etc.) and for transfer of process fluids/products to rail cars and/or tanker trucks for shipment. Flexible hoses may also be installed within process piping systems to mitigate the effects of thermal expansion, vibration, or movement during normal operations. Some sites will maintain several flexible hoses to be used as needed in multiple services. Flexible hoses come in a variety of different construction materials and designs. Owner-operators should ensure the design of the flexible hose is compatible with the process service in which it is used. In addition, have appropriate quality assurance and test and inspection systems in place to ensure the mechanical integrity of the hose is maintained while in service.

5 Piping Design and Construction

5.1 Design and Construction Standards

Piping should be fabricated in accordance with the appropriate construction standards for the application. Some commonly used construction standards are ASME B31.3 and ASME B31.1.

5.2 Methods of Construction

5.2.1 Pipe Joining Methods

5.2.1.1 General

The common joining methods used to assemble piping components are welding, threading, and flanging. Welded joints are most used to connect piping spools and components. Some owner-operators still rely on threaded joints in SBP and where piping is connected to equipment that requires periodic maintenance. Flanged joints are most used where piping is connected to equipment or other flanged valves and fittings. Cast iron piping and thin-wall tubing require special connections/joining methods due to inherent design characteristics.

5.2.1.2 Threaded Joints

Threaded joints are generally limited to auxiliary piping in noncritical service (minor consequence should a leak occur) that has a nominal size of 2 in. (51 mm) or smaller. Threaded joints for NPSs of 24 in. (610 mm) and smaller are standardized (see ASME B1.20.1).

Lengths of pipe can be joined by any of several types of threaded fittings (see 4.4). Couplings, which are sleeves tapped at both ends for receiving a pipe, are normally used to connect lengths of threaded pipe. When it is necessary to remove or disconnect the piping, threaded unions or mating flanges are required (see 5.2.1.4). Threaded joints that are located adjacent to rotating equipment or other specific sources of high vibration can be especially susceptible to failure due to fatigue. Special consideration should be given to these situations.

5.2.1.3 Welded Joints

5.2.1.3.1 General

Where welded joints are used, the joints are either butt-welded (in various sizes of pipe) or socket-welded (typically NPS 2 and smaller).

5.2.1.3.2 Butt-welded Joints

Butt-welded connections are the type most widely utilized in industry. The ends of the pipe, fitting, or valve are prepared (beveled) and aligned with adequate root opening in accordance with ASME B16.25 or any other end preparation that meets the welding procedure specification, permitting the ends to be joined by fusion welding.

5.2.1.3.3 Socket-welded Joints

Socket-welded joints are made by inserting the end of the pipe into a recess in a fitting or valve and then fillet welding the joint. Two lengths of pipe or tubing can be connected by this method using a socket-weld coupling. Figure 11 illustrates a cross section of a socket-welded joint.

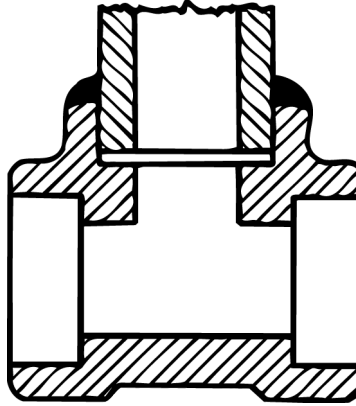

Figure 11—Cross Section of a Socket-welded Tee Connection

5.2.1.3.4 Welded Branch Connections

Many piping failures occur at pipe-to-pipe welded branch connections. Branch connections often fail because they are subject to higher-than-normal stresses. These may be caused by excessive structural loadings from unsupported valves or piping, vibration, or thermal expansion, or other configurations that promote high stress. The result is concentrated tri-axial stresses (e.g. bending and torsional) that can cause fatigue cracking or other types of failures. Where joints are susceptible to such failures, a forged piping tee typically offers better reliability because it removes the weld from the point of highest stress concentration. Self-reinforced branch connections also can offer better reliability if they are properly welded to the main pipe using appropriate weld procedures and meet the manufacturer's recommendations for full penetration welds.

5.2.1.4 Flanged Joints

Flanged joints are made by bolting two flanges together with some form of gasket between the seating surfaces. The gasket surfaces can be flat and range from serrated (concentric or spiral) to smooth (depending on the type of gasket, gasket material, and service conditions), or grooves can be cut for seating metal-ring gaskets. Flanged joints should be assembled by trained and qualified personnel (see Appendix A of ASME PCC-1). Consideration should be given to establishing a finished joint examination process. See 6.2 on flanged joint leakage.

Figure 12 illustrates common flange facings for various gaskets. The common types of flanges are weld neck, slip-on welding, threaded, blind, lap joint, and socket-welded. Each type is illustrated in Figure 13.

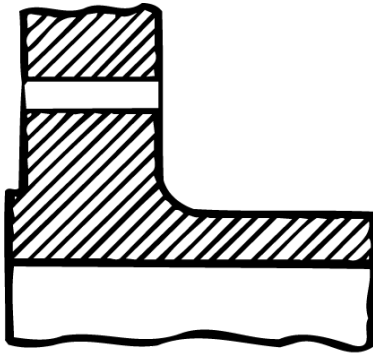

a) Raised face

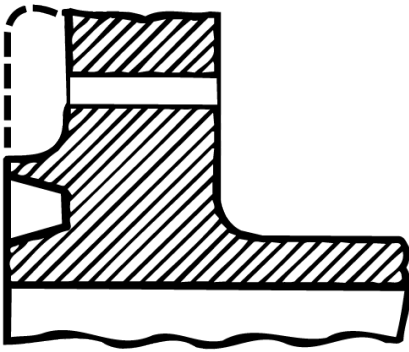

b) Ring-joint face

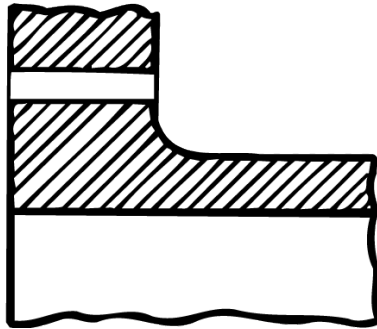

c) Flat face

Figure 12—Flange Facings Commonly Used in Refinery and Chemical Plant Piping

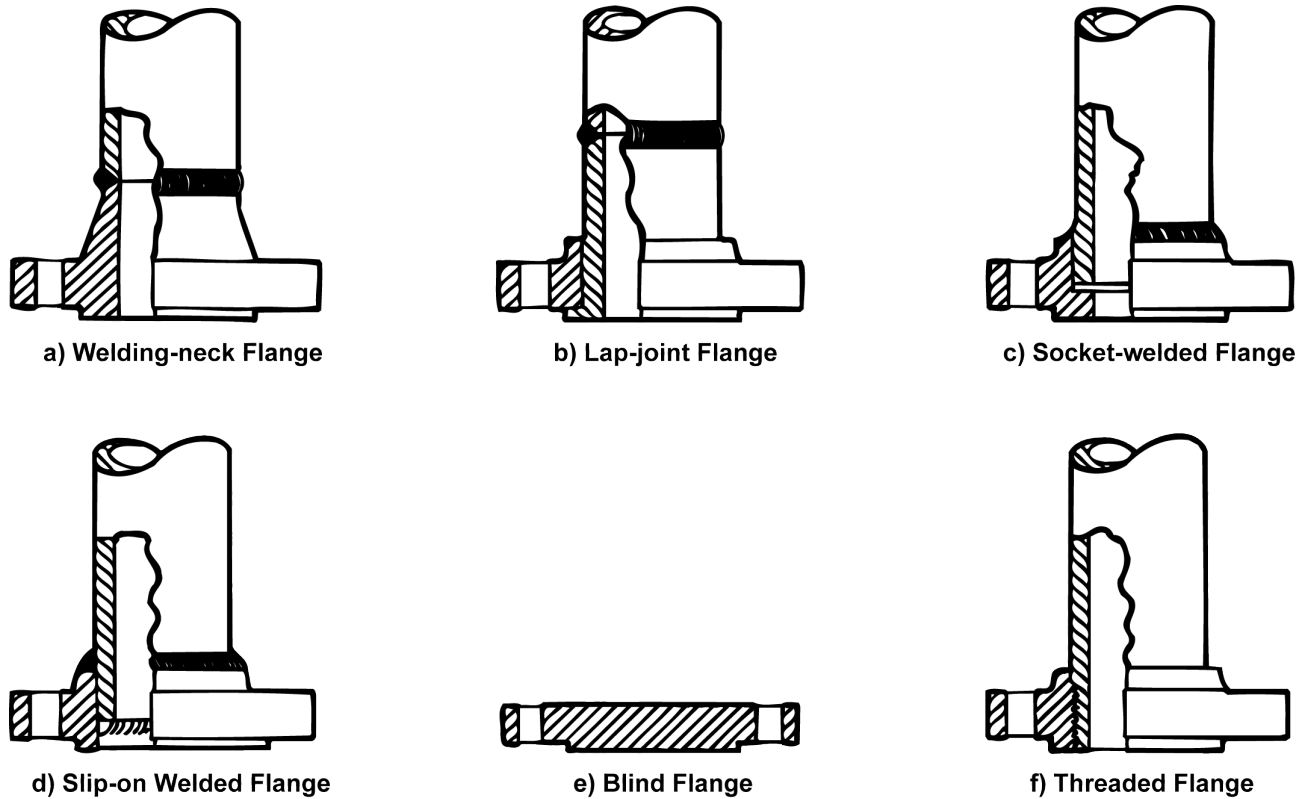

Figure 13—Types of Flanges

5.2.1.5 Cast Iron Pipe Joints

Cast iron pipe joints can be of the flanged, packed, sleeve, hub-and-spigot-end or hub-and-plain-end, or bell-and-spigot-end or bell-and-plain-end type. Push-on joints with rubber or synthetic ring gaskets are available. Clamped joints are also used. The hub-and-plain-end joint is shown in Figure 14. Figure 15 illustrates cross sections of a bell-type mechanical joint, a sleeve connection, and a typical proprietary connection (see 5.2.1.7). These types of joints are rarely used in process piping service because of their low toughness and tendency toward brittle fracture.

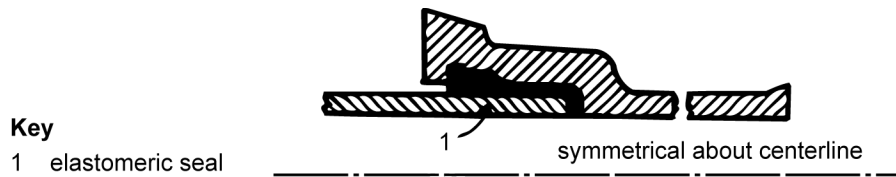

Figure 14—Cross Section of a Typical Bell-and-Spigot Joint

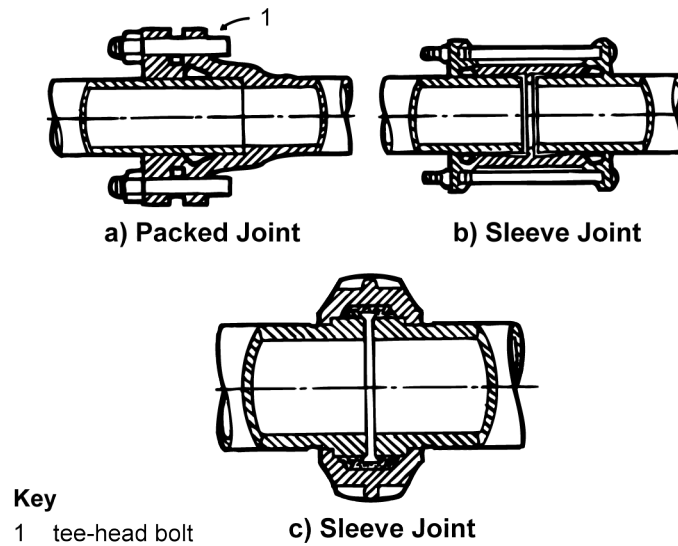

Figure 15—Cross Sections of Typical Packed and Sleeve Joints

5.2.1.6 Tubing Joints

Tubing can be joined by welding, soldering, or brazing or by using flared or compression fittings. Figure 16 illustrates flared and compression joints. Tubing joints should be assembled by trained and qualified personnel. Consideration should be given to establishing a finished joint examination process in accordance with tubing joint manufacturer's recommendations.

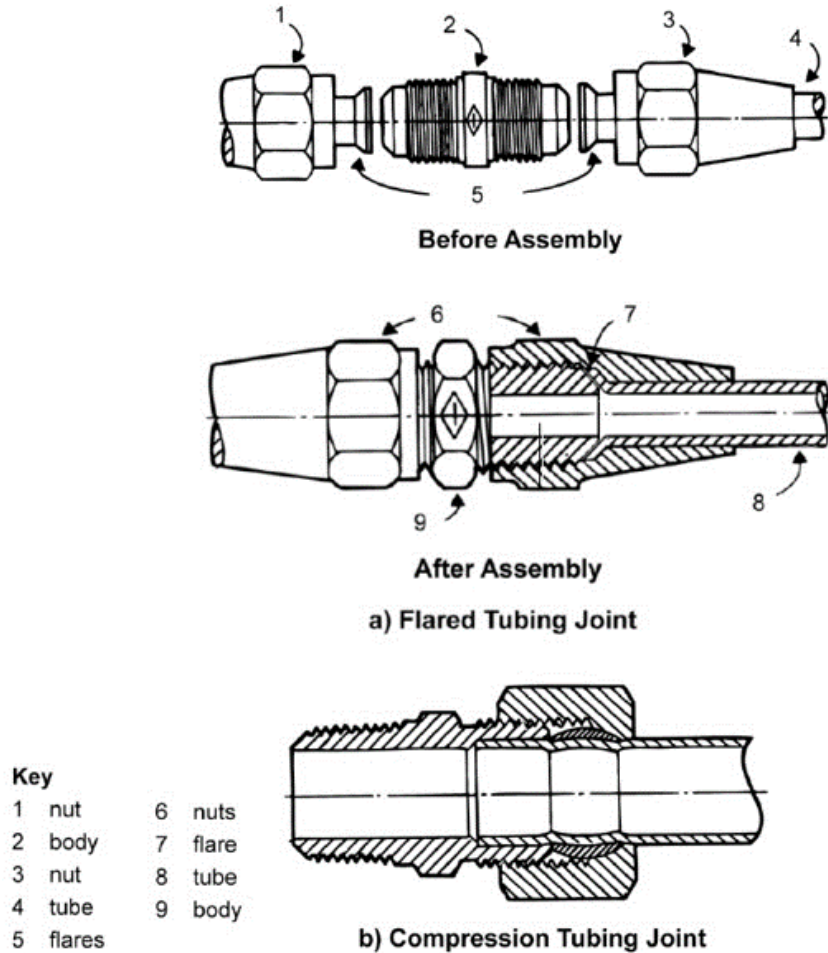

Figure 16—Cross Sections of Typical Tubing Joints

5.2.1.7 Special Joints

Proprietary joints are available that incorporate unique gaskets, clamps, and bolting arrangements. These designs offer some advantages in some services over conventional joints in certain services, including the following:

- higher pressure and temperature ratings;
- smaller dimensions;
- easier installation—axial and angular alignment requirements are less stringent;
- greater force and moment toleration.

5.2.1.8 Nonmetallic Piping Joints

5.2.1.8.1 General

There are several methods of joining FRP pipe and fittings. Joints in nonmetallic piping are often of several different designs depending upon the manufacturer of the pipe. Some common joint designs in FRP pipe systems include a bell and spigot, butt and wrap, taper-taper, and flange-flange.

5.2.1.8.2 Bell and Spigot/Taper-taper

Bell-and-spigot and taper-taper joints are created by inserting the spigot end into the bell end. Proper surface preparation, insertion, and adequate adhesive are the key to making these types of joints.

5.2.1.8.3 Butt and Wrap

Butt-and-wrap joints involve butting plain end pipe together and applying layers of resin and fiber reinforcement layers around the joint. These types of joints should be done by qualified personnel.

NOTE Fitting thickness is often greater than the matching pipe thickness. The proper taper of the fitting thickness is required to make the proper butt-and-wrap joint.

5.2.1.8.4 Flange-flange

Proper flange joint makeup involves the use of appropriate gaskets, bolt torques, and alignment. Using a calibrated torque wrench helps ensure proper torquing and avoids damage by overstressing the FRP flanges. Proper flange alignment, flatness, and waviness according to the specification can prevent damage when torquing to specified values. Full-face gaskets are typically used for bolting full-face flanges. Flanges bolted to raised-face connections should be evaluated individually for required torque values and proper gasket requirements.

5.2.2 Pipe Fabrication

5.2.2.1 General

Pipe fabrication is the process of cutting, beveling, and welding piping components, such as pipes, tees, elbows flanges, etc. to provide a means to safely transport or process liquids, gases, and solids.

5.2.2.2 Seamless Pipe

Seamless pipe is made as a continuous tube with no longitudinal weld. This type of pipe is generally known to withstand higher pressure and is widely used in industry. A common carbon steel seamless pipe is ASME SA106.

5.2.2.3 Seam Welded Pipe

Seam welded pipe is formed by using a rolling machine to roll the longer sides of plate together to form a cylinder and then welding the seam together. The most common method of joining the seam is electric resistance welding. This produces a weld seam that cannot be seen or felt. This pipe is generally used in lower-pressure applications and services that would not be selectively corrosive to welds/heat-affected zone.

5.3 Materials of Construction

5.3.1 Base Material

Piping can be made from any material that can be rolled and welded, cast, or drawn through dies to form a tubular section. The two most common carbon steel piping materials used in the petrochemical industry are ASTM A53 and ASTM A106. The industry uses both seamless and electric resistance welded piping for process services, depending upon current economics and the potential for accelerated corrosion of the weld seam in service. Piping of a nominal size larger than 16 in. (406 mm) is usually made by rolling plates to size and welding the seams. Pipe can be centrifugally cast and then machined to any desired thickness.

5.3.2 Pipe Linings

Internal linings can be incorporated into the piping design to reduce corrosion, erosion, product contamination, and pipe metal temperatures. The linings can generally be characterized as metallic and nonmetallic.

Metallic liners are installed in various ways, such as cladding and weld overlay.

- a) Clad pipe has a metallic liner that is an integral part of the plate material rolled or explosion bonded before fabrication of the pipe.
- b) Corrosion-resistant metal can also be applied to the pipe surfaces by various weld overlay processes.
- c) Metallic liners can be made of any metal resistant to the corrosive or erosive environment, depending upon its purpose. These include stainless steels, high alloys, cobalt-based alloys, etc.

Nonmetallic liners can be used to resist corrosion and erosion or to insulate and reduce the temperature on the pipe wall. Some common nonmetallic lining materials for piping are concrete, castable refractory, plastic, and thin-film coatings.

5.3.3 Nonmetallic Piping

5.3.3.1 General

Nonmetallic materials are not covered by API 570. The term “nonmetallic” has a broad definition, but this section refers to the fiber-reinforced plastics group encompassed by the generic acronyms FRP (fiber-reinforced plastic) and GRP (glass-reinforced plastic). Another group of materials, for example high- and low-density polyethylene and polyvinyl, have a homogeneous structure produced by extrusion and are outside the scope of this document.

Nonmetallic materials have limited application to specific piping systems in the process industry, such as in utilities. For example, typical service applications of FRP piping include service water, process water, cooling medium, potable water, sewage/gray water, nonhazardous waste, nonhazardous drains, nonhazardous vents, chemicals, firewater ring mains, firewater deluge systems, and produced and ballast water. Nonmetallic materials have significant advantages over more familiar metallic materials, but they also have unique construction and deterioration mechanisms that can lead to premature failures if not addressed adequately.

The design of these piping systems is largely dependent on the application. Many companies have developed their own specifications that outline the materials, quality, fabrication requirements, and design factors. It is noted that other codes and standards have requirements and guidance. In particular:

- a) ASME B31.3, Chapter VII, covers design requirements for nonmetallic piping;
- b) the American Water Works Association is an organization that also provides guidance on FRP pipe design and testing.

These codes and standards, however, do not offer guidance as to the right choice of corrosion barriers, resins, fabricating methods, and joint systems for a particular application. The user should consider other sources, such as resin and pipe manufacturers, for guidance on their application.

5.3.3.2 FRP Pipe Manufacturing

Historically, while many of the failures in FRP piping are related to poor construction practices, a poor understanding of the application to a service or the manufacturing of the materials can also lead to failure.

For example, a lack of familiarity with the materials can lead to a failure to recognize the detail of care that must be applied in construction.

FRP materials require understanding of their manufacturing process and their service limitations. For example:

- a) each manufacturing technique will generate a different set of physical properties;
- b) each resin system has a temperature limitation, and each joint system has its advantages and disadvantages.

FRP piping is manufactured in many ways. Every service application should be reviewed for proper resin, catalyst, corrosion barrier (liner) composition, and structural integrity. Although FRP is corrosion resistant, using the wrong resin or corrosion barrier can cause premature failure.

FRP pipe can experience ultraviolet (UV) degradation over time if not adequately protected. Adding a UV inhibitor in the resin will help prevent premature fiber blooming caused by UV. The user should consider this option for all FRP piping applications and be aware that this would be a supplemental specification.

Standardized FRP piping systems commonly called “commodity piping” are manufactured for a variety of services and are sold as products with a predetermined design, resin, corrosion barrier, and structure. Piping manufacturers typically have a quality control specification that identifies the level of quality and allowable tolerance that is built into their product.

Custom fabricated pipe is typically designed and manufactured for a specific application. The resin, catalyst system, corrosion barrier, and structure are specified, and the pipe is manufactured to a specification and to a specified level of quality and tolerances.

5.3.3.3 Qualification of Assemblers

The qualification of bonders and jointers is as important for FRP fabrication as the qualification of welders is for metal fabrication. Due to limitations in NDE methods, the emphasis must be placed on procedure and bonder qualifications and testing.

Similarly, because the material stiffness is much less than metal and because FRP has different types of shear, small-bore connections will not withstand the same shear stress, weight loadings, or vibrations that are common with metallic piping. Supporting attachments, such as valves, etc., on small-bore connections should be analyzed in detail to prevent premature failure of the system.

5.3.3.4 Inspection

All FRP piping should be inspected by a person who is knowledgeable in the curing, fabrication, and quality of FRP materials. The level of inspection should be determined by the user. ASME RTP-1—Table 6-1 can be used as a guide to identify liner and structure imperfections that are common in FRP laminates.

The FRP inspector should verify by documentation and inspection that the piping system has been built with the proper materials, quality, hardness, and thickness as requested in the pipe specification. A final inspection should be performed at the job site to ensure that the pipe has not experienced any mechanical damage during shipment or assembly.

6 Reasons for Inspection

6.1 General

The primary purposes of inspection are to observe, report, and quantify damage (see API 571) and then to specify needed repairs or replacements. Planning for inspection entails identifying credible damage mechanisms for the purposes of directing the inspection activity. The inspection activity requires obtaining information about the physical condition of the piping, which will lead to determining the causes of any deterioration and the rate of deterioration. By developing a database of inspection history, the user can predict and recommend future repairs and replacements, act to prevent or retard further deterioration, and most importantly, prevent loss of containment. These actions should result in increased operating safety, reduced maintenance costs, and more reliable and efficient operations. API 570 provides the basic requirements for a piping inspection program which addresses these issues and concerns.

6.2 Process and Personnel Safety

A leak or failure in a piping system can be a minor inconvenience for low-consequence fluids or it can become a potential source of a process safety incident for higher-consequence fluids depending on the temperature, pressure, contents, and location of the piping. Piping in a petrochemical plant typically contains flammable fluids, acids, alkalis, toxic fluids, and other harmful fluids that would make leaks potentially hazardous to exposed personnel. Leaks in these kinds of piping systems can also have environmental consequences associated with their failure. Adequate inspection is a prerequisite for maintaining piping systems in a safe, reliable condition.

Leakage can occur at flanged joints in piping systems for a variety of reasons, including corrosion, cracking, bolt tightness issues, and gasket issues. In addition, thermal expansion issues can cause leaks particularly for joints in high-temperature services during start-ups and shutdowns, and sometimes during normal operation. For these reasons, process plant practices should include quality assurance/control procedures to help ensure flanged joint integrity after maintenance activities where the joints have been disassembled. Procedures typically include, for example, proper gasket and fastener selection, assembler qualifications, proper assembly instruction, inspection, and testing requirements. Refer to ASME PCC-1 for flange joint assembly practices.

6.3 Regulatory Requirements

Regulatory requirements may cover those piping systems that could affect personnel or process safety and environmental concerns. Process safety regulations, such as OSHA 29 *CFR* 1910.119 in the United States, have mandated that equipment, including piping, that handles significant quantities of hazardous chemicals be inspected according to accepted codes and standards, which includes API 570. Local and state regulations may also cover process piping inspection and maintenance.

6.4 Reliable Operation

In addition to the need for inspection to provide for process and personnel safety, thorough inspection, data analysis, and maintenance of detailed inspection/repair/replacement records of piping systems are essential to the attainment of acceptable process reliability to meet the business plan. Piping maintenance and replacement schedules are developed to coincide with scheduled maintenance turnarounds to avoid unplanned outages and the consequences of lost production opportunities.

7 Inspection and Monitoring Planning

7.1 Background

An inspection plan is developed and implemented for those piping systems within the scope of API 570. However, other piping systems may also be included in the inspection program and accordingly have an inspection plan.

An inspection plan should contain the inspection tasks, the scope of the inspection, and the schedule required to monitor identified damage mechanisms and ensure the mechanical integrity of the piping components in the system. API 570 defines the minimum contents of an inspection plan.

Inspection plans for piping systems can be maintained in spreadsheets, hardcopy files, and proprietary inspection software databases.

7.2 Developing an Inspection Plan

7.2.1 General

An inspection plan is often developed through the collaborative work of the inspector, piping engineer, corrosion specialist, and operating personnel. The team should consider several pieces of information, such as operating temperature ranges, operating pressure ranges, process fluid corrosive contaminant levels, piping material of construction, piping system configuration, process stream mixing, and inspection/maintenance history.

In addition, other information sources can be consulted, for example API and NACE (AMPP) publications, to obtain industry experience with similar systems. This information provides a basis for defining the types of damage and locations for its occurrence.

Knowledge of the capabilities and limitations of NDE techniques allows the proper choice of examination technique(s) to identify specific damage mechanisms in specific locations. Refer to API 571 and ASME PCC-3 for more information regarding inspection techniques and their limitations/uses per specific damage mechanisms.

Ongoing communication with operating personnel when process changes and/or upsets occur that could affect damage mechanisms and rates are critical to keeping an inspection plan updated. IOWs help set key thresholds for process changes affecting mechanical integrity. See API 584 for further information.

For piping systems, inspection plans should address the following:

- a) condition monitoring locations (CMLs) for specific damage mechanisms;
- b) piping contact points at pipe support;
- c) pipe supports and support appurtenances;
- d) CUI;
- e) injection points;
- f) process mixing points;
- g) soil-to-air (concrete-to-air) interfaces (SAIs);
- h) deadleg sections of pipe;

- i) PMI;
- j) auxiliary piping;
- k) critical utility piping as defined by owner-operator;
- l) vents/drains;
- m) threaded pipe joints;
- n) internal linings;
- o) critical valves;
- p) expansion joints.

In addition, consideration should be given to incorporating miscellaneous piping and tubing that may be overlooked from the routine circuit inspection programs into the inspection plan. These circuits may still pose a reliability concern and should be considered in the inspection plan. Examples include instrument bridles for equipment connecting to piping circuits, temporary piping used during maintenance outages, and swing-out spools.

Inspection plans may be based on various criteria but should include a risk assessment or fixed intervals as defined in API 570. For more information on risk-based inspection (RBI), see 8.2.

7.2.2 Identification of Damage Mechanisms

Oil refinery and chemical plant piping can be subject to internal and external damage mechanisms. This piping carries a range of fluids that can be highly corrosive, erosive, and prone to stress corrosion cracking (SCC) or subject to material damage in service. In addition, both aboveground and buried piping is subject to external corrosion. The inspector should be familiar with the credible damage mechanisms for each piping system. API 571 has been developed to give the inspector added insights on various causes of damage. Figure 17, Figure 18, Figure 19, and Figure 20 illustrate several examples of corrosion and erosion of piping.

If an inspection of an area of piping indicates damage is occurring, the piping upstream and downstream of this area, along with associated equipment, should also be inspected. Additionally, if deterioration is detected in pressure equipment, associated piping should also be inspected.

Each owner-operator should provide specific attention to the need for inspection of piping systems that are susceptible to the following specific types and areas of deterioration:

- a) injection points;
- b) process mixing points;
- c) deadlegs;
- d) CUI;
- e) SAIs;
- f) service specific and localized corrosion;
- g) erosion and erosion-corrosion;

- h) environmental cracking;
- i) corrosion beneath linings and deposits;
- j) fatigue cracking;
- k) creep cracking;
- l) brittle fracture;
- m) freeze damage;
- n) contact point corrosion;
- o) dew-point corrosion.

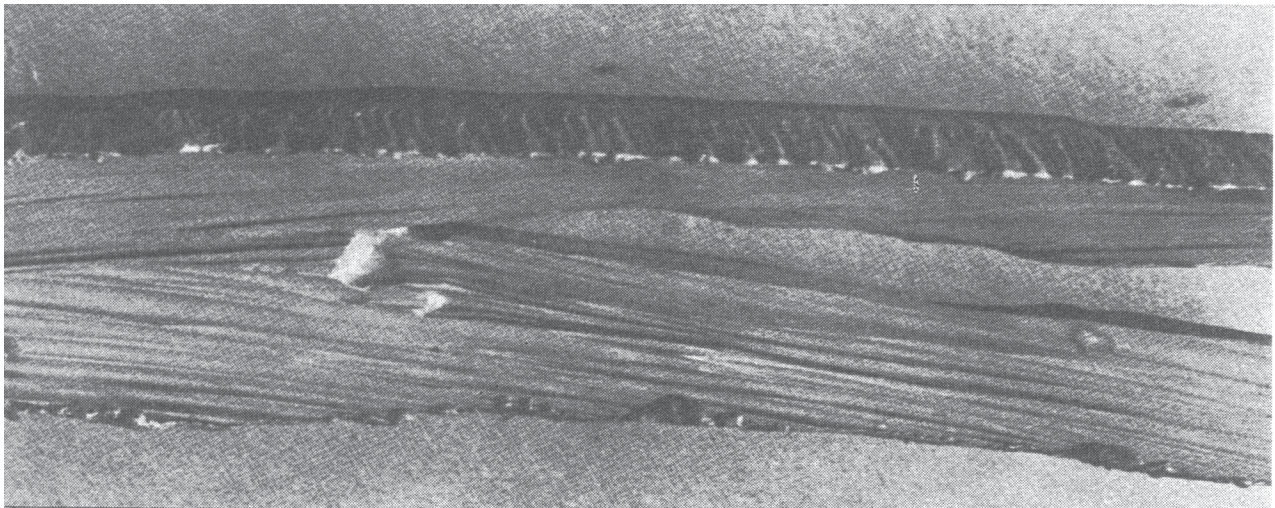

Figure 17—Erosion of Piping

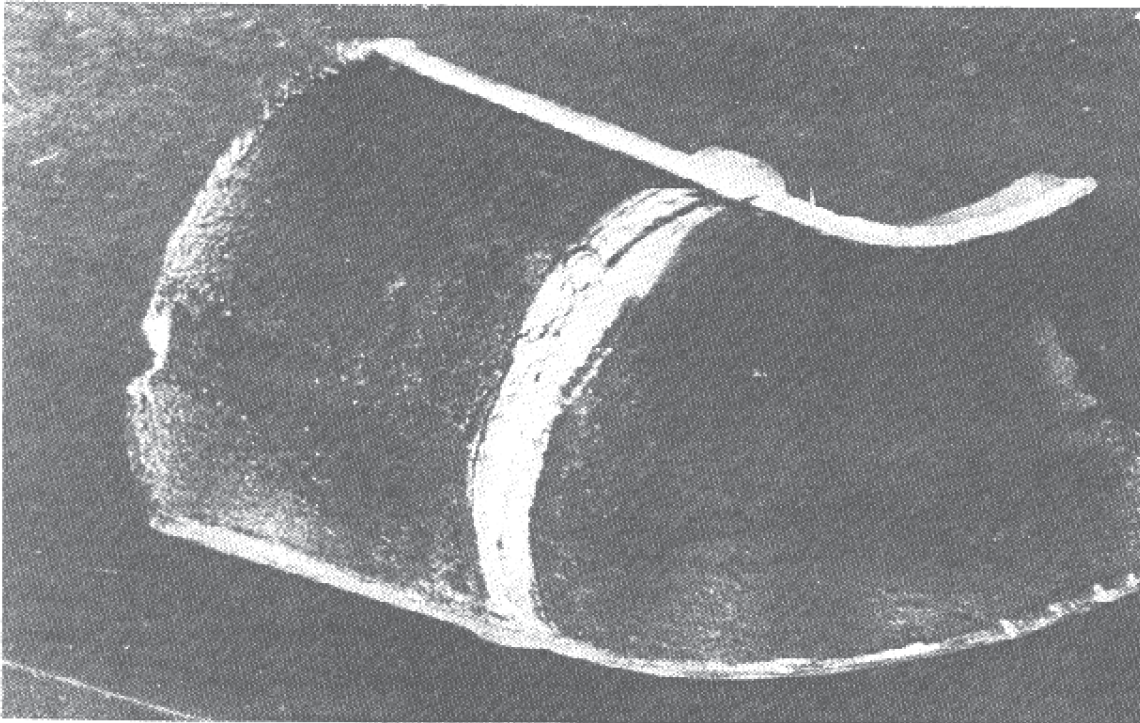

Figure 18—Corrosion of Piping

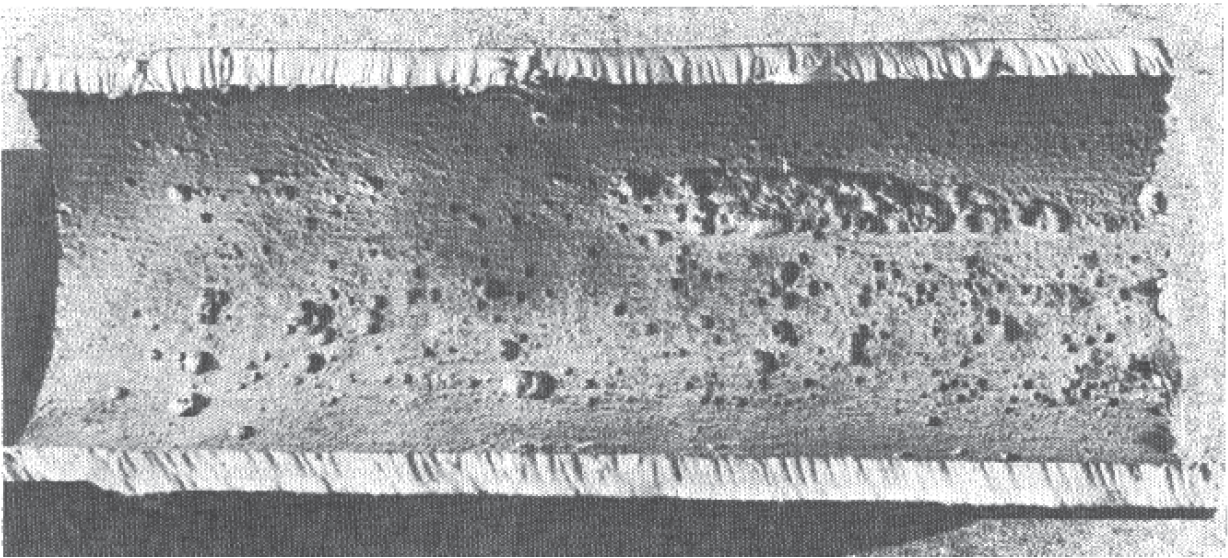

Figure 19—Internal Corrosion of Piping



Figure 20—Severe Atmospheric Corrosion of Piping

7.2.3 Selecting Inspection Activities

Inspection plans should address the credible damage mechanisms as identified by a corrosion specialist and/or the unit Corrosion Control Document, as detailed in API 970. Identifying and understanding the credible damage mechanisms that can cause deterioration of piping and piping components is key in developing an effective inspection plan. Without adequately identifying what credible damage mechanisms are applicable, a proper inspection plan cannot be performed.

API 571, in conjunction with process and equipment information, can be utilized to assign credible damage mechanism and the associated inspection methods/techniques. Once all credible mechanisms have been established, the appropriate inspection technique(s) should be aligned with the corresponding modes of damage.

To determine if piping is subject to damage and will require internal inspection, on-stream inspection, and/or thickness monitoring, the following factors should be considered:

- 1) credible damage mechanisms: the availability of process corrodents, such as water, oxygen, H_2S , etc., that may act on the materials of construction, as determined by a corrosion specialist.
- 2) process controls (e.g. IOWs) in place to identify when the process has been changed such that it becomes damaging to the material.
- 3) new process design; if the piping is in a new process where there is some uncertainty about whether the process will work as designed, it should not be designated as being in noncorrosive service until proven through operation and inspection.

- 4) process stability; if the process is such that a small change in operation can introduce conditions where the damage mechanism could become active versus the case where introduction of a corrodent (e.g. water) would not be compatible with operation (e.g. the cryogenic portion of an ethylene plant).
- 5) presence of protection against known damage mechanism, such as corrosion-resistant weld overlay, cladding, coating, lining, or refractory; some piping may not require much, if any, inspection because of lack of credible damage mechanisms; however, consideration for failed protective measures should be established.

Typical examples of systems with no credible internal damage mechanism are as follows:

- 1) ethylene plant piping operating under cryogenic conditions;
- 2) liquefied natural gas plants downstream of the mercury removal beds and water removal;
- 3) process units alloyed up for product purity where any corrosion would result in the product not meeting specifications;
- 4) new piping replaced in-kind with a proven history of no credible internal damage mechanism but was replaced due to external damage mechanism, such as CUI;
- 5) refrigerant grade fluid piping that are without any contamination.

7.2.4 Locations for Inspection

CMLs should be selected once credible damage mechanisms have been identified. The number of CMLs selected will depend on the technique's probability of detection, degree of localization of the damage, and how predictable the damage mechanism is. Additional CMLs may also be added, for piping with high likelihood or high risk of failure.

Understanding the factors and conditions that affect the probability a damage mechanism will be active is important in developing a focused inspection plan and selecting the appropriate location for inspection. Previous inspection results can be used to identify active mechanisms and better predict areas to be inspected. Piping susceptible to uniform damage can be inspected at any convenient location; however, it may be necessary to inspect larger areas or employ multiple techniques to ensure that localized damage is detected.

Matching the various surface and volumetric NDE techniques to localized corrosion damage mechanisms is key in capturing the correct corrosion data. Predicting where damage will occur, specifically localized damage, is difficult even when the credible damage mechanism(s) are well understood. Consultation with a corrosion specialist and/or review of the process unit Corrosion Control Document can help in understanding CML selection and placement for localized damage mechanisms. Selecting appropriate inspection locations for equipment subject to localized damage is as critical as applying the appropriate technique. If sufficient levels of inspection have been performed over time, the results of those inspections could be used to identify locations of damage. Once established, these mechanisms and their associated modes can be used in conjunction with equipment availability (will equipment be shut down or remain on-stream) to plan inspection techniques.

Visual checks of the external parts of piping should be performed periodically. These inspections may be conducted at comparatively short intervals (e.g. compared to a 10-year internal inspection interval), the interval depending on the service, and/or previous condition of the piping involved. External inspection of piping should be conducted in accordance with API 570—Section 6.4. It is important to understand the process conditions prior to the external visual inspection to determine whether CUI inspections should be planned. See API 583 for more information on issues that may assist in the development of CUI inspection plans.

The list of techniques identified for the piping inspection should be compared against internal or process-based inspection and maintenance requirements (e.g. potential fouling or mechanical problems) to ensure that all areas are assessed as needed. This information is combined into one set of inspection activities. Then, based on damage rates and remaining life, the appropriate frequency should be identified (see Section 8).

7.2.5 Interval-based Inspection Plans

Interval-based inspection plans base specific inspection intervals upon the types of piping inspection required, as well as the types of damage mechanisms and damage rates that have been assigned. The types of inspection where maximum intervals are suggested in API 570 include external visual, CUI, thickness measurement, injection point, SAI, SBP, auxiliary piping, and threaded connections.

The interval for inspections is based on several factors, including the corrosion rate and remaining life calculations, piping service classification, applicable jurisdictional requirements, and the judgment of the inspector, the piping engineer, or a corrosion specialist. The governing factor in the inspection plan for many piping circuits is the piping service classification.

7.2.6 Classifying Piping Service

According to API 570—Section 6.3.4, all process piping shall be classified according to the consequence of failure, except for piping that has been planned based on RBI results. Piping classes vary from Class 1 (high consequence) to Class 3 (low consequence). Additionally, there is a Class 4 for services that are essentially nonflammable and nontoxic. Adding more CMLs in appropriate locations to higher-consequence piping subject to higher corrosion rates or localized corrosion and monitoring those CMLs more frequently may reduce the likelihood of high-consequence events. This strategy gives a more accurate prediction of retirement dates and reduces inspection uncertainty in the piping where reliability is more important.

Factors to consider when classifying piping are as follows:

- a) toxicity;
- b) volatility;
- c) flammability;
- d) location of the piping with respect to personnel and other equipment;
- e) experience and history.

7.3 Monitoring Process Piping

7.3.1 General

The single most frequent damage mechanism leading to pipe replacement is corrosion. For this reason, an effective process piping inspection program should include monitoring piping thickness from which corrosion rates, remaining life, next inspection dates, and projected piping retirement dates can be determined.

A key to the effective monitoring of piping corrosion is identifying and establishing CMLs. CMLs are designated areas in the piping system where measurements are periodically taken. Ultrasonic thickness measurements are obtained within examination points on the pipe. Thickness measurements may be averaged within the examination point. By taking repeated measurements and recording data from the same points over extended periods, damage rates can more accurately be calculated or assessed.

Some of the factors to consider when establishing the corrosion-monitoring plan for process piping are as follows:

- a) classifying the piping service in accordance with API 570 or risk ranking based on RBI analysis;
- b) categorizing the piping systems into piping circuits of similar corrosion behavior (e.g. localized, general, and environmental cracking);
- c) identifying susceptible locations where accelerated damage has occurred or is expected;
- d) accessibility of the CMLs for monitoring when localized corrosion is not predicted;
- e) RBI results identify high-risk piping circuits and/or specific piping locations.

7.3.2 Piping Systems

Developing piping systems and circuits based on credible/identified damage mechanisms enables the development of concise inspection plans and forms the basis for improved data analysis. Refer to API 570 for the characteristics of defining piping systems.

The following are some examples of documenting piping systems. Piping systems can be documented on the process flow diagrams (PFDs) as described below and contain the following information for each.

- a) Systems can be highlighted by unique color coding and name.
- b) Piping system nomenclature may utilize conventions that are readily understood within the facility, ideally providing a common language between operating and inspection personnel. Typically, the piping system identifier is appended to a unit prefix, with piping system and individual piping circuits incrementing from unit feed to product streams.
- c) Each piping system may have other characteristics associated with them documented, including the boundaries, general process concerns, IOW parameters, general damage mechanisms, and process corrosion control measures.

7.3.3 Piping Circuits

Complex process units or piping systems are divided into piping circuits to manage the necessary inspections, calculations, and recordkeeping. When establishing the boundary of a particular piping circuit, the inspector may also size it to provide a practical package for recordkeeping and performing field inspection. By identifying like environments and damage mechanisms as circuits, the spread of calculated corrosion rates of the CMLs in each circuit is reduced. Proper selection of components in the piping circuit and the number of CMLs are particularly important when using statistical methods to assess corrosion rates and remaining life. Figure 21 is an example of one way to break piping up into circuits.

Piping circuit layout and associated CMLs are often identified on inspection piping sketches to aid the inspector in performing inspection tasks. See 14.2.1 for information on piping sketches.

Each material of construction has specific corrosion/erosion characteristics and may respond uniquely when placed into different operating environments. Differing materials of construction may not have the same resistance to damage within the same operating environment. Therefore, the material of construction is a key element in determining credible damage mechanisms and/or rate of damage based on the operating environment. Circuit breaks should be placed when there is a change in the piping materials of construction, which can cause a change in corrosive/erosive behavior. A metallurgist/corrosion engineer experienced in the process unit under review should be consulted for the assignment of damage mechanisms and/or rate of damage for differing materials of construction.

Several factors can affect the rate and nature of pipe wall corrosion. Individual circuits should be limited to piping components within the system where the damage rate and type of damage (common damage mechanisms) are consistent. Considerations for the limits of the piping circuit may include, but are not limited to, the following items:

- a) piping metallurgy;
- b) process fluid and its phase (e.g. gas, liquid, two-phase, solid);
- c) flow velocity;
- d) temperature;
- e) pressure;
- f) changes in temperature, velocity, pressure, direction, phase, metallurgy, or pipe cross section;
- g) injection of water or chemicals;
- h) process fluid contaminants;
- i) mixing of two or more streams;
- j) piping external conditions, including coating/painting, insulation, and soil conditions, as applicable;
- k) stagnant flow areas (e.g. deadlegs).

When actual corrosion rates of a circuit differ from what is expected, a review should be performed to identify the potential reason. However, as a first step, the reading should be validated. If the reading proves to be valid, the corrosion specialist should be consulted to help review process parameters that may have changed and caused a shift in the corrosion rate. IOWs can be used to monitor for and adjust to changing conditions, and the associated IOW data can be part of this review. It is important to note that if no reason is found for the shift in corrosion rate, it could be attributed to the uncertainty associated with the measurement for the last two readings. The results of the review should be reflected in changes to the inspection plan, if required.

Piping circuits should be identified with common damage mechanisms to facilitate inspection planning and data analysis and will generally have the following characteristics:

- a) common materials of construction;
- b) common design conditions;
- c) common operating conditions;
- d) common set (one or more) of damage mechanisms;
- e) common expected corrosion rate;
- f) common expected damage locations/morphology.

For risk-based programs, piping circuits may be further subdivided based on risk level. For example, a pump discharge or upstream of a control valve may have the same corrosion characteristics as pump suction or downstream of the control valve, but the risk may be greater on the high-pressure segments due to higher leak rate potential. In such cases, the higher-pressure components may be assigned to a separate circuit.

In addition, based on the nature of the corrosion, damage type/morphology, and piping metallurgy, circuits may contain the following:

- a) multiple line numbers;
- b) multiple line sizes;
- c) both primary and secondary piping components;

- d) short deadlegs (e.g. the greater of $< 2D$ or 8 in. in length, drains/vents and blinded/capped tee runs), depending on the potential for deadleg/under-deposit corrosion.

Piping circuits are typically shown on inspection isometric drawings and/or the piping and instrument diagram (P&ID). They may be highlighted with a unique color coding (or symbol), name and/or number. Additional piping circuit attributes that may be identified on the isometric drawings include the following:

- a) the boundaries of the circuit;
- b) numbered injection or mix point locations;
- c) contact support locations for inspection;
- d) SAI locations;
- e) the extent of insulation;
- f) CUI/CUF locations for inspection.

Each piping circuit is typically documented with additional information, such as the following:

- a) credible damage mechanisms;
- b) materials of construction;
- c) damage type—degree of generalized or localized corrosion expected;
- d) generalized locations where inspection points should be specified based on operating conditions and metallurgy;
- e) specific concern locations or areas— injection point impingement, deadlegs/drains for condensed acid, etc.;
- f) specific process concerns;
- g) process corrosion control measures.

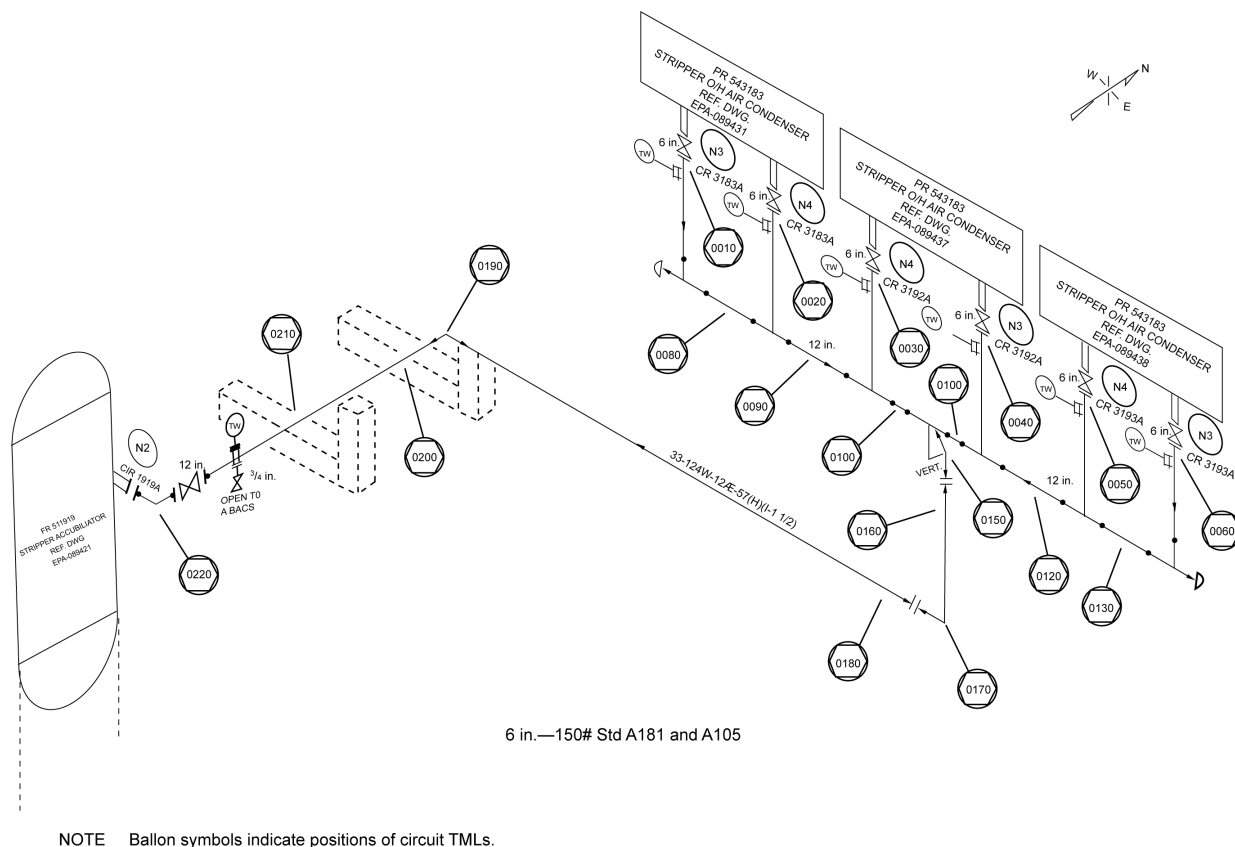

Figure 21—Piping Circuit Example

7.3.4 Statistical Analysis of Circuit CMLs

Although a statistical analysis can be performed on any circuit, the results may be misleading unless the circuit is well defined as outlined in 7.3.3, where the circuit boundaries ideally encompass the minimum number of common damage mechanisms exhibiting a similar corrosion rate. Refer to Annex C for a more detailed description of statistical analyses.

Given the nature of piping thickness data and its many sources of error, all data used in any statistical analysis should be carefully validated. The validation should include steps to identify and eliminate typical issues, such as undocumented replacements, anomalous readings, calibration shifts, or data entry errors, to minimize the errors.

There are numerous related statistical techniques that may be employed in the analysis of circuit thickness data, and it is not the intent within this document to define or recommend any specific methodology. The owner-operator may elect to use any appropriate methodology or techniques (either corrosion rate or thickness-based analysis) as a means to establish representative corrosion rates and estimate minimum remaining thickness and future inspection dates.

Any statistical analysis methodology utilized should be documented. Documentation should include any requirements, assumptions, limitations, cautions, etc. associated with the statistical analysis methodology. Care should be taken to ensure that the statistical treatment of the data results in a conservative representation of the various pipe components within the circuit. Ideally, the analysis should result in some (or all) of the following information for the piping circuit:

- measure and ensure that the data distribution is appropriate for the analysis methodology selected;
- provide an estimate of the standard error of the data;
- identify any significant outlying data/points that do not fit within the analysis parameters or distribution;
- provide an estimate of the minimum sample size (data population) for the statistical methodology used (statistical significance);
- provide for a statistical corrosion rate (or thickness) and confidence for the circuit;
- identify if there may be mixed modes of corrosion damage (localized/generalized);
- identify if there may be a shift in the corrosion rate data over time.

7.3.5 Identifying Locations Susceptible to Accelerated Corrosion

In the presence of certain corrodents, corrosion rates are normally increased at areas of increased velocity and/or turbulence. Elbows, reducers, mixing points, control valves, and orifices are examples of piping components where accelerated corrosion can occur because of increased velocity and/or turbulence. Such components are normally areas where an inspector would locate additional CMLs in a piping circuit. However, the inspector should also be aware that areas of no flow, such as deadlegs (see 7.4.2), can cause accelerated corrosion and may need additional CMLs. In situations where cracking is anticipated, a CML may be established to monitor the rate of cracking.

7.3.6 Accessibility of CMLs

When assigning CMLs, the inspector should consider accessibility for monitoring them. CMLs at grade level normally provide the easiest accessibility. Other areas with good accessibility are equipment platforms and ladders. In some piping systems, the nature of the active damage mechanisms will require monitoring at locations with limited accessibility. In these cases, inspection planning should decide among scaffolding, portable man lifts, or other methods to provide adequate access.

7.4 Inspection Guidance for Location-specific Damage

7.4.1 Injection and Mixing Points

7.4.1.1 Injection Points

API 570 identifies injection points for additional monitoring and/or enhanced inspection during operation. This was done in recognition that injection points have caused significant equipment integrity problems due in part to their design and operation. For example, some injection points may have been installed without close attention simply because they were perceived as small add-ons with little potential for causing a problem. However, these also should be included in inspection planning.

Many different types of process additives are used to maintain reliability and optimal performance of plant operations. Typically, additives are injected into piping systems through small branch connections either directly or through a quill or spray nozzle. The locations at which these additives are introduced into process streams are commonly referred to as injection points.

An additive may be one of the following types:

- a) a proprietary chemical, such as a corrosion inhibitor, antifoulant, or oxygen scavenger;
- b) a water stream injected to dissolve salt deposits;
- c) dilute corrosive process components.

Some common injection systems found in refinery applications include the following:

- a) ammonium polysulfide injection into sour gas streams (FCC, coker, sour water stripper);
- b) steam/condensate injection into flue gas and catalyst piping;
- c) washwater injection (continuous and intermittent) into hydroprocessing effluent to control corrosion, which may be caused by NH_4HS and NH_4Cl salts. Refer to API 932-B—Section 6.8.1 and Table 2, for additional details;
- d) crude desalter washwater;
- e) caustic injection into crude feed;
- f) caustic injection into reformer regeneration section piping;
- g) chloride [e.g. PERC (perchloroethylene)] injection into reformer reactor feed piping;
- h) methanol/condensate injection into reformer reactor system piping;
- i) ammonia or neutralizing amine injection into crude tower overhead systems;
- j) cold H_2 quench injection into hydroprocessing reactor system piping;
- k) filming amine inhibitor injection into fractionation and gas plant overhead piping.

Several corrosion mechanisms associated with injection points have become apparent over the years. Many of these problems have resulted in highly localized deterioration. Corrosion damage associated with injection points may produce corrosion rates one order of magnitude higher than reported for the main process streams, with localized losses being the most common form of problem.

Inspection practices geared to scanning areas of the piping are necessary to be able to detect localized corrosion. Problems with injection points have generally been avoided when specification, design, training, operation, and condition monitoring were adequately carried out. After installation of injection systems, the following should be reviewed:

- a) injection system, including the process operating window, anticipated conditions, equipment design, materials of construction, anticipated chemical and physical interactions, and monitoring/inspection requirements, has been documented and installed hardware has been checked;
- b) procedures and measurements in place to verify injection system performance is accomplishing its objective and not causing unanticipated process problems;
- c) inspection plan, in accordance with API 570, in place to check the injection point and related equipment for damage related to the injection.

During the design and period audit of the injection systems, the following would typically be considered:

- a) the injection system was designed to achieve its process and reliability objectives;
- b) the range of desired injection rates and the range of process conditions expected in the receiving stream were considered;
- c) the ultimate destination of the injectant and its components were considered;

- d) design of the injection as a system, including the injection point, supply system, instrumentation, and control was considered;
- e) potential credible damage mechanisms were anticipated, and designs and materials of construction to achieve the desired pressure equipment reliability were chosen;
- f) an MOC process was used in implementing or modifying the injection, as a way to ensure that changes were adequately thought out;
- g) operating and maintenance personnel were trained on the proper operation and servicing of the injection equipment;
- h) injection quills and nozzles that project into the process stream were visually inspected for fouling and loosening of joints and those subject to fatigue were liquid penetrant inspected;
- i) spray patterns of nozzles were tested;
- j) anti-blowout features of retractable injection hardware were inspected.

For more thorough and complete information, see NACE SP0114.

7.4.1.2 Process Mixing Points

Process mixing points occur where pipe components combine two process streams of differing composition, temperature, or other parameter that could cause damage. Mixing points can be subject to accelerated damage either from corrosion or mechanical mechanisms (e.g. thermal fatigue). Problems with mixing points have generally been avoided when specification, design, training, operation, and condition monitoring were adequately carried out.

Some examples of process mixing points include the following:

- a) mixing of a chloride-containing stream from a catalytic reformer (e.g. naphtha) with a wet hydrocarbon stream from elsewhere;
- b) mixing a low-temperature, high-sulfur-containing hydrocarbon stream with a high-temperature stream is an issue when bulk fluid temperature is increased where high-temperature sulfidation becomes active;
- c) mixing hydrogen into a hydrocarbon stream where the stream temperatures are significantly different;
- d) mixing of streams from hydroprocessing hot and cold separators;
- e) mixing where high-temperature corrosion (e.g. sulfidation) can become an issue if the overall fluid temperature is increased.

The inspector, unit process engineer, and corrosion specialist will typically review PFDs to identify susceptible process mixing points and define the extent of the mix point circuit. More intensive inspection chosen for the damage mechanism is usually required at specific mixing points. This could include close grid thickness surveys, UT scanning techniques, and profile radiographic examination (RT) for corrosion. Other NDE techniques (e.g. angle beam UT, PT, etc.) may be appropriate when inspecting for thermal fatigue cracking. Under some conditions, users may apply injection point inspection requirements to susceptible process mixing points.

Some mixing points may incorporate proven technology resulting in complete mixing of each stream. These mixing points may not fall within the intended scope/definition of corrosive mixing points and may not require any special emphasis inspections.

7.4.1.3 Mixing Point Thermal Fatigue Considerations

It has been noted that the failure in design to adequately encompass several considerations has and can lead to thermal fatigue failures. These considerations include mixing effectiveness, flow regime, materials of construction, stream composition and stream volume, and evaluation of normal operating conditions combined with the likelihood/frequency of those conditions.

Table 2 is an example that may be used for screening the material, fluid types and temperature difference between the two streams at a mixing point to determine whether thermal fatigue may be a concern. Table 2 does not address corrosion at mix points that can occur at lower-temperature differentials. If the temperature difference between two process streams exceeds the number below, a thermal sleeve may be needed in order to prevent thermal fatigue.

Owner-operators should develop their own specific criteria for screening and addressing thermal fatigue at mixing points.

Table 2—Mix Point Thermal Fatigue Screening Criteria

Flow Medium		Delta Temperature (°F)	
Main Pipe	Secondary Pipe	Ferritic	Austenitic
Gas	Gas	450	300
Liquid	Liquid	450	300
Liquid	Gas	450	300
Gas	Liquid	275	125

7.4.1.4 Effectiveness of Mixing and Flow Regime

When two streams are combined, turbulence starts the mixing process, and the effectiveness will depend on the degree of penetration by the mixing stream and whether the two streams are miscible or immiscible. If the streams are miscible, then a single phase will be formed, but dispersion and dissolution are time dependent. Complete mixing may not develop until 100 pipe diameters or more downstream; inspection plans should consider the area where incomplete mixing is predicted. If the streams are immiscible, two phases may remain in the mixed stream or a third phase may form downstream of the mixing point (e.g. amine salt deposition).

The flow regime that develops depends on the following:

- a) stream velocity;
- b) relative amounts/densities of the phases;
- c) size and orientation of both lines.

Flow regimes are different in horizontal and vertical lines because of gravity. Fully developed flow may not occur until many pipe diameters downstream.

7.4.1.5 Mixing, Contacting, or Wetting

Injection and mixing points involve mixing, contacting, or wetting.

- a) **Mixing**—The rate of mixing is improved by an increase in velocity of the injected stream, which can be accomplished by injecting through a quill or spray nozzle.
- b) **Contacting**—Contacting or intimate mixing of the separate phases is improved by maximizing the area between the phases (e.g. by a spray nozzle).
- c) **Wetting**—In single-phase streams, wetting of walls by injected fluid is readily achieved. In two-phase streams, wetting is dependent on the flow regime with annular, bubble, and froth flow enhancing wetting of the walls, whereas stratified and wavy flow will impede wall wetting.

7.4.1.6 Quantity of Injected/Mixed Water

In some situations, the quantity of water needs to be calculated carefully to ensure that sufficient unvaporized water remains to fulfill the function and not exacerbate corrosion. Process engineers should check this periodically. Water quality can also affect corrosion rates.

See NACE SP0114 for additional information.

7.4.2 Deadlegs

The corrosion rate in deadlegs can vary significantly from adjacent active piping. The inspector should monitor the wall thickness on selected deadlegs, including both the stagnant end and the connection to an active line. Examples of deadlegs include the following:

- a) in systems such as tower overhead systems and hydrotreater units where ammonium salts are present, corrosion can occur in the area of the deadleg where the metal is at the salting or dew-point temperature;
- b) in hot piping systems, the high-point area can corrode due to convective currents set up in the deadleg.

For such systems, extensive inspection coverage using techniques such as UT scanning and profile RT may be necessary in order to locate the area where dew-point or ammonium-salt corrosion is occurring.

Overall, consideration should be given to removing deadlegs that serve no further process purpose.

Additionally, water can collect in deadlegs, which can freeze in colder environments, resulting in pipe rupture.

7.4.3 SAI

External corrosion can occur at the interface where partially buried pipe or buried pipe egresses from soil (and/or concrete). Note that areas where pipe is unintentionally, but permanently, contacting the soil (e.g. due to soil movement) should be treated as SAIs as well. Typically, the corrosion can extend from 12 in. (30 cm) below to 6 in. (15 cm) above the soil surface.

Inspection at grade should include checking for coating damage, bare pipe, and pit depth measurements. If significant corrosion is noted, thickness measurements and excavation may be required to assess whether the corrosion is localized to the SAI or can be more pervasive to the buried system. Thickness readings at SAIs can expose the metal and accelerate corrosion if coatings and wrappings are not properly restored.

Figure 22 is an example of corrosion at an SAI, although it had been wrapped with tape. If the buried piping has satisfactory cathodic protection, as determined by monitoring in accordance with API 570, excavation is required only if there is evidence of coating or wrapping damage. Experience has shown that corrosion could occur under the tape even though it appears to be intact. Consideration should be given to excavating

down 12 in. (300 mm) and removing the tape for inspection. Use of an appropriate NDE in lieu of the excavation and tape removal can be done to inspect for possible corrosion underneath the tape.

If the buried piping is uncoated at grade, consideration should be given to excavating 6 in. (150 mm) to 12 in. (300 mm) deep to assess the potential for hidden damage. Alternately, specialized UT techniques (e.g. guided wave) can be used to screen areas for more detailed evaluation.

At concrete-to-air and asphalt-to-air interfaces for buried piping without cathodic protection, the inspector should look for evidence that the caulking or seal at the interface has deteriorated and allowed moisture ingress. If such a condition exists on piping systems over 10 years old, it may be necessary to inspect for corrosion beneath the surface before resealing the joint.

See API 571 for additional information on corrosion at SAIs.



Figure 22—SAI Corrosion

7.4.4 Service-specific, Localized Corrosion

While there are many types of internal damage mechanisms possible from the process service, the following are some examples of service-specific, localized corrosion mechanisms and where they might be expected for the inspector to consider in developing inspection plans:

- a) downstream of injection and mixing points and upstream of product separators (e.g., hydroprocessor reactor effluent lines);

- b) dew-point corrosion in condensing streams (e.g. overhead fractionation);
- c) unanticipated acid or caustic carryover from processes into nonalloyed piping systems, or in the case of caustic, into non-postweld heat treated steel piping systems;
- d) where condensation or boiling of acids (organic and inorganic) or water is likely to occur;
- e) where naphthenic or other organic acids can be present in the process stream;
- f) where high-temperature hydrogen attack can occur (see API 941);
- g) ammonium salt condensation locations in hydroprocessing streams (see API 932-B);
- h) mixed-phase flow and turbulent areas in acidic systems, also hydrogen grooving areas;
- i) where high-sulfur streams at moderate-to-high temperatures exist;
- j) mixed grades of carbon steel piping in hot corrosive oil service [500 °F (260 °C)] or higher temperature and sulfur content in the oil greater than 0.5 % by weight;

NOTE Nonsilicon-killed steel pipe (e.g. ASTM A53/A53M and API 5L) can corrode at higher rates than silicon-killed steel pipe (e.g. ASTM A106) in high-temperature sulfidation environments. Differences in silicon content can lead to accelerated metal loss of specific pipe components (see API 939-C).

- k) under-deposit corrosion in slurries, crystallizing solutions, or coke-producing fluids;
 - l) chloride carryover in catalytic reformer units, particularly where it mixes with other wet streams;
 - m) welded areas subject to preferential attack;
 - n) “hot spot” corrosion on piping with external heat tracing;
- NOTE In services that become much more corrosive to the piping with increased temperature (e.g. sour water and caustic in carbon steel), corrosion or SCC can develop at hot spots that develop under low-flow conditions.
- o) steam systems subject to “wire cutting,” graphitization, or where condensation occurs;
 - p) locations subject to high-temperature sulfidation corrosion where residence times resulting from low-flow conditions may result in increased corrosion; susceptible locations include elbows, along the top of horizontal sections of the line, and areas where localized heating may occur, i.e. double, or triple heat trace areas and in stagnant and low-flow piping systems with thermally induced currents (thermosiphon).

Where a temporary (or swing-out) piping spool has not been removed prior to process operation start-up, it should be verified that the temporary piping is either effectively isolated from the process (such as a double-block valve or isolation blind) or that the temporary piping is of adequate material and mechanical design for the continued process operation, including potential no flow conditions. One particular concern is raised for temporary piping of inadequate material that may be subject to high-temperature sulfidation or other damage mechanisms if left exposed to the process. If the temporary piping is isolated and left for a significant period, lockout/tagout can be a means to prevent inappropriate and inadvertent service.

7.4.5 Contact Point Corrosion

Localized corrosion at pipe support contact points is the result of crevice corrosion due to deposits that contain corrosive species, water, and oxygen typical of an externally corrosive environment. More corrosion can be expected in moist climates, marine climates, and where contact between the pipe and its supports is less of a “point” and more of an “area.” If undetected and/or not mitigated, contact point corrosion can lead to leaks.

7.4.6 Piping Supports

7.4.6.1 External Corrosion at Supports

Corrosion of supports, and their associated pipework, may occur in areas of protective coating breakdown where water and airborne debris become trapped (often referred to as “contact point corrosion”). Support design (i.e. support beams) can significantly contribute to this issue. Corrosion rates can be increased by local factors. Elevated temperatures from hot piping (e.g. steam piping) can increase corrosion, including fireproofed supports. Other factors, such as heat tracing or steam trap drain outlets, or where moisture is increased, such as from proximity to cooling towers and vegetation (creating a wet environment on the underside of the pipe and on any supports in the proximity), all can contribute to locally high corrosion rates.

Crevice corrosion can occur under any partially or nonwelded shoe, doubler plate, wrapper, or half-sole plate. Considerations should also be given to intermittent environmental conditions, such as testing of fire suppression deluge systems, etc.

Dummy leg supports may trap water and airborne debris, leading to corrosion of both the support and the pipe. When constructed using pipe, consideration should be given to capping all open-ended supports with fully welded caps or plates and providing a drain hole no smaller than 1/4 in. (6 mm) at the lowest position. For horizontal dummy legs, drain holes should be provided at both ends, and the dummy leg should slope slightly away from the pipe it is supporting.

7.4.6.2 Internal Corrosion at Supports

The cooling effect of a support on elevated temperature pipe may be sufficient to cause product or water condensation on the inside of the pipe. In some process services, this condensation may contribute to accelerated internal corrosion.

7.4.6.3 Other Damage Mechanisms at Supports

Several other damage mechanisms can occur at pipe supports and should be inspected for including the following.

- a) Fretting, Overstress, or Coating Damage at Supports due to Thermal Expansion—Thermal expansion and contraction due to temperature changes can damage protective coating systems and/or overstress both pipe and pipe supports.
- b) Galvanic Corrosion at Supports—Galvanic corrosion is associated with the use of two or more materials of differing value in the galvanic series, in close proximity to each other. For example, carbon steel supports welded to stainless steel piping may be subject to corrosion at a higher rate than the stainless steel piping.
- c) CUI at Supports—Supports that penetrate insulation systems may provide a potential for water ingress and subsequent CUI due to poor sealing at the penetration.
- d) Environmental Cracking at Support—In predominantly alkaline process environments (e.g. amines and caustic), welding of supports to carbon steel piping either with or without postweld heat treatment (PWHT) can cause internal environmental cracking as a result of residual stresses.
- e) External Cracking at Supports—Austenitic stainless steel piping may be susceptible to ECSCC where there is a source of chlorides above a threshold temperature. Pipe supports that trap water against the pipe can contribute to the susceptibility of cracking.
- f) Foundation/Concrete Plinth Deterioration (Including Subsidence)—Deterioration of foundations and plinths are often a direct result of overloading the support and/or extended service life.
- g) Vibration/Movement/Misalignment—Pipe vibration, movement, and misalignment can create a potential for fatigue, fretting, and/or overstressing of pipe and support members. Proper anchors, restraints, and movement allowances/guides should be considered during support design. This includes available travel of spring hangers.

7.4.7 Stainless Steel Tubing in Chloride Service

One service-specific damage mechanism is chloride pitting and CSCC of tubing. The 18Cr-8Ni family of stainless steels, such as Types 304 and 316, are commonly used for tubing materials of construction. However, it should be noted that even though these tubing materials may be resistant to many chemical fluids, they are susceptible to pitting and CSCC if:

- a) There is a presence of chlorides.
 - Externally, chlorides may come from insulation, PVC insulation jacketing, the atmosphere, rain (especially in marine environments), deluge water systems, washdown of surrounding decks and roads, etc.
 - Internally, chlorides can be common in many process streams and may be introduced by hydrotest water.
 - Concentration mechanisms, such as local evaporation of water, can also increase susceptibility to cracking.

b) There is a presence of water.

c) There is exposure to temperatures above about 140 °F (60 °C).

NOTE It should be noted that in some instances chloride pitting and CSCC can occur at temperatures below 140 °F (60 °C), such as low pH environments or in components with high residual stress.

d) There is tubing material stress.

- This is common from residual stresses imparted during tube manufacturing processes or during installation processes, such as tube bending and compression fitting makeup.

Tubing failures due to CSCC and/or pitting can be too unpredictable to manage through inspection efforts; therefore, a materials or corrosion specialist/engineer should be consulted for alloy recommendations used in aggressive environments. Consideration should be given to using materials such as Alloy 825 (for many elevated temperature refining applications), Alloy C-276 [for sour water or hot hydrofluoric (HF) services where oxidizing species are present], and Alloy 20Cb3 (for sulfuric acid applications), or other available high alloys because of their improved resistance to CSCC and/or pitting.

7.4.8 Inspection of Underground Piping

7.4.8.1 General

Inspection of buried process piping (not regulated by the Department of Transportation) is different from other process piping inspections because significant external deterioration can be caused by corrosive soil conditions. Figure 23 illustrates external corrosion occurring to underground piping despite the use of tape wrap. Important references for underground piping inspection include NACE SP0169, NACE SP0274, and API 570—Section 9.

Note that the inspection of SAIs is generally not considered to be an inspection of the respective buried piping as the inspection plan for damage mechanisms can vary significantly between the SAI and that for buried piping.

7.4.8.2 Types and Methods of Inspection and Testing

7.4.8.2.1 Above-grade Visual Surveillance

Indications of leaks from buried piping can include moist ground or actual seepage of product carried in the underground piping, a change in the surface contour of the ground, discoloration of the soil, softening of paving asphalt, pool formation, bubbling water puddles, or noticeable odor. Surveying the route of buried piping is one method to identify problem areas. All lines should be inspected at and just below the point where they enter earth, asphalt, or concrete because serious corrosion frequently occurs at such locations.

Small unmanned aerial systems, often referred to as “drones,” can be utilized to support or replace ground-based surveys. Unmanned aerial systems can utilize either a camera or a mix of a camera and an infrared system to provide this assistance. Additional sensing technology that may detect particular chemical species (such as methane) may also be employed. Compliance with the local regulatory regulations and safe operation of flights is required. Those employing these technologies should assure themselves of the detection capabilities and verify the performance of such equipment.

7.4.8.2.2 Close-interval Potential Survey

Close-interval potential surveys are used to locate corrosion cells, galvanic anodes, stray currents, coating problems, underground contacts, areas of low pipe-to-soil potentials, and other problems relating to cathodic protection.

A close-interval pipe-to-soil potential survey measures the potential of the pipe to the soil directly over the pipe, at predetermined intervals between measurements, usually at 2.5 ft, 5 ft, 10 ft, or 20 ft (0.8 m, 1.5 m, 3 m, or 6 m). The pipe contact can be made at an aboveground pipe attachment. Examples of a standard-type pipe-to-soil potential survey on a bare line are shown in Figure 24 and Figure 25.

Corrosion cells can form on both bare pipe and coated pipe with holidays where the bare steel contacts the soil. Since the potential at the area of corrosion will be measurably different from an adjacent area on the pipe, the location of the corrosion activity can be determined by this survey technique.



Figure 23—Underground Piping Corrosion beneath Poorly Applied Tape Wrap

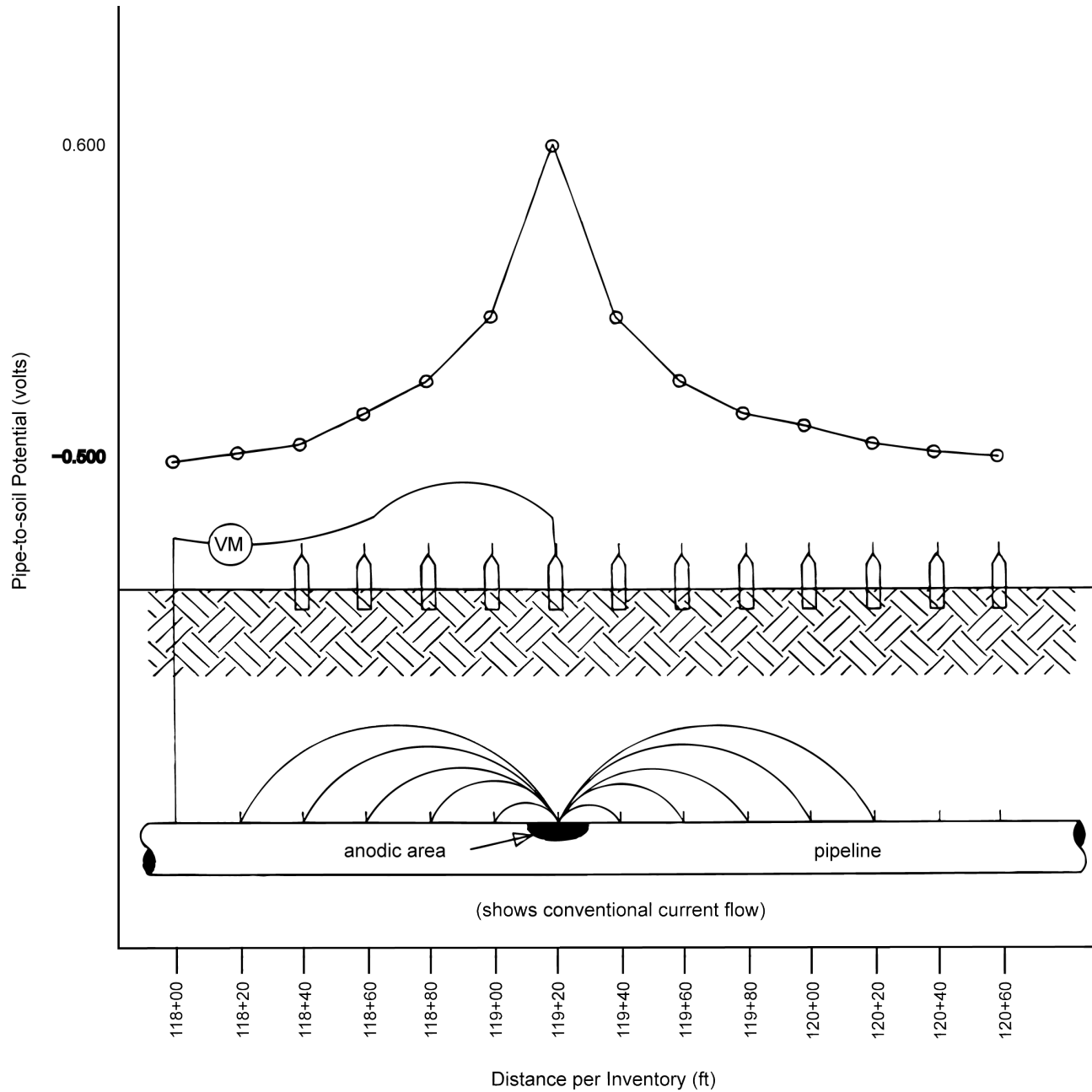

NOTE This structure is not under cathodic protection.

Figure 24—Pipe-to-Soil Internal Potential Survey Use to Identify Active Corrosion

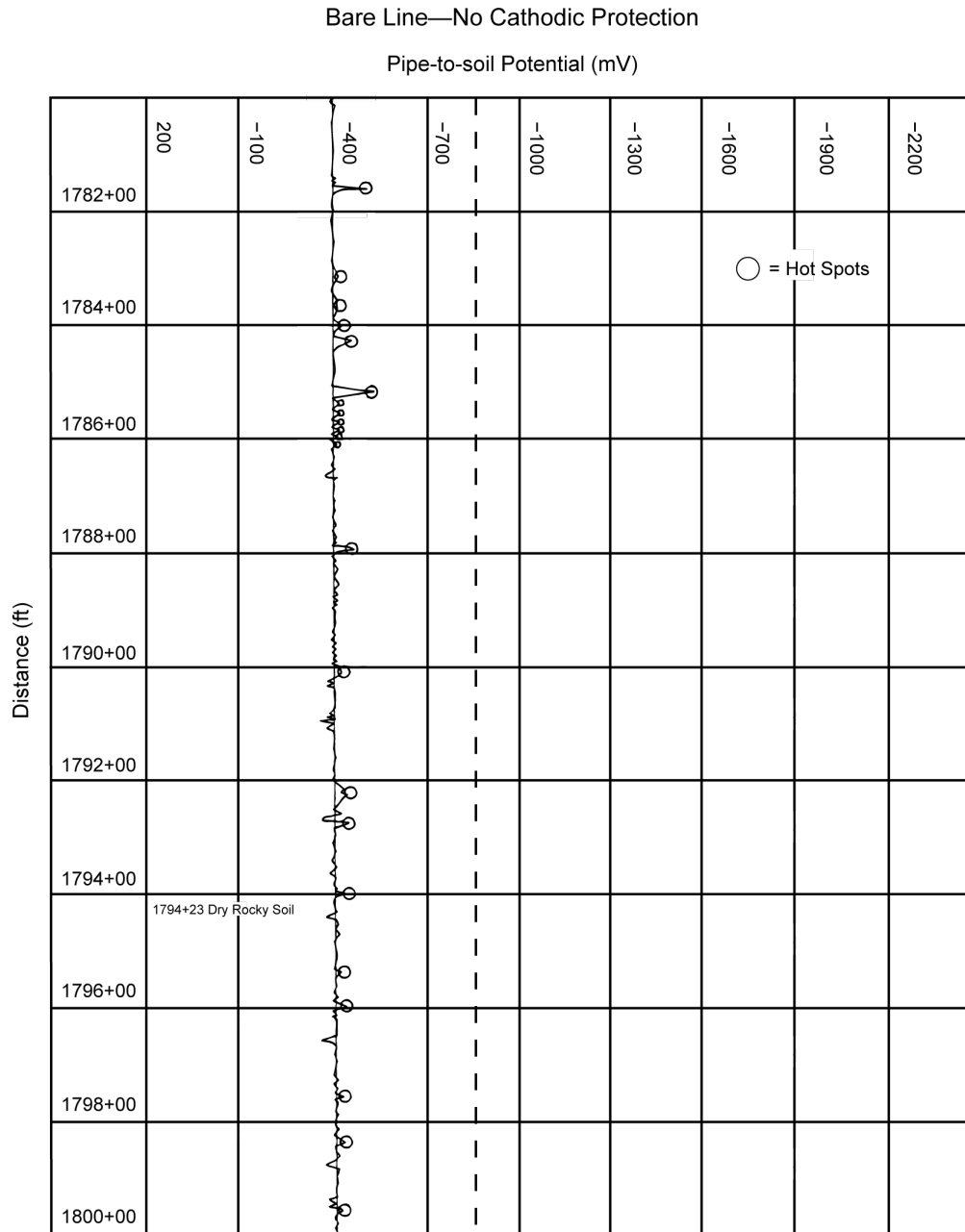

Figure 25—Example of Pipe-to-Soil Potential Survey Chart

7.4.8.3 Holiday Pipe Coating Survey

There are two key applications for employing holiday surveys.

- 1) It should be used on newly coated and installed piping to ensure that the coating is intact and holiday free. The holiday pipe coating survey (e.g. direct current voltage gradient) can be used to locate external coating flaws on buried coated pipes.
- 2) More often it is used to evaluate coating serviceability for buried piping that has been in service for an extended period.

From survey data, the coating effectiveness and rate of coating deterioration can be determined. This information is used for both predicting corrosion activity in a specific area and forecasting the replacement of the coating for corrosion control.

The frequency of pipe coating holiday surveys is usually based on indications that other forms of corrosion control are ineffective. For example, on a coated pipe where there is a gradual loss of cathodic protection potentials, or when an external corrosion leak occurs at a coating defect, a pipe coating holiday survey may be used to evaluate the coating.

7.4.8.4 Soil Resistivity Testing

Soil resistivity measurements can be used for the relative classification of soil corrosivity. Corrosion of bare or poorly coated piping is often caused by a mixture of different soils in contact with the pipe surface. The corrosiveness of the soils can be determined by a measurement of the soil resistivity. Lower levels of resistivity are relatively more corrosive than higher levels, especially in areas where the pipe is exposed to significant changes in soil resistivity.

There are three well-known methods of determining resistivity. These are the Wenner Four-pin Method, the soil bar (AC bridge), and the soil box. The procedures for the use of each of these three methods are simple in concept. Each one measures a voltage drop caused by a known current flow across a measured volume of soil. This "resistance" factor is used in a formula to determine the resistivity of the soil. Both the soil bar and the soil box use a multiplication factor to determine the soil resistivity. This factor should be imprinted on the bar or box.

Measurements of soil resistivity using the Wenner Four-pin Method should be in accordance with ASTM G57. The Four-pin Method uses the formula:

$$\text{Resistivity (ohm} \times \text{cm)} = 191.5 \times d \times R$$

where

- 191.5 is a constant that takes into account the mathematical equation for the mass of the soil and a conversion factor to convert feet to centimeters;
- d is the distance in feet between any of the equally spaced pins (with all of the pins in a straight line);
- R is a resistance factor of the voltage drop across the two inner pins, divided by the induced current flow in the earth between the two outer pins.

The depth that the pins are inserted into the earth should be small compared to the pin spacing (see Figure 26). The following conditions should be considered in four-pin soil resistivity measurements:

- a) all underground structures should be excluded from the measurement;
- b) all of the pins should be in a straight line and equally spaced;
- c) the depth of the pins inserted into the ground should be less than 4 % of the spacing;
- d) the soil resistivity meter should be designed to exclude any effect of extraneous AC or DC currents.

In cases of parallel pipes or in areas of intersecting pipelines, the Four-pin Method may not be applicable. Other methods include using a soil bar or a soil box.

A schematic illustrating use of a soil bar is shown in Figure 27. The soil bar is typically inserted to the depth in the soil where the resistivity is to be taken. An AC bridge-type meter is used to balance and read the indicated resistivity. Suggestions for use of the soil bar include the following:

- a) use of a standard prod bar to provide the initial hole;
- b) avoiding the addition of water during or after opening the hole;
- c) applying pressure on the soil bar after insertion into the open hole.

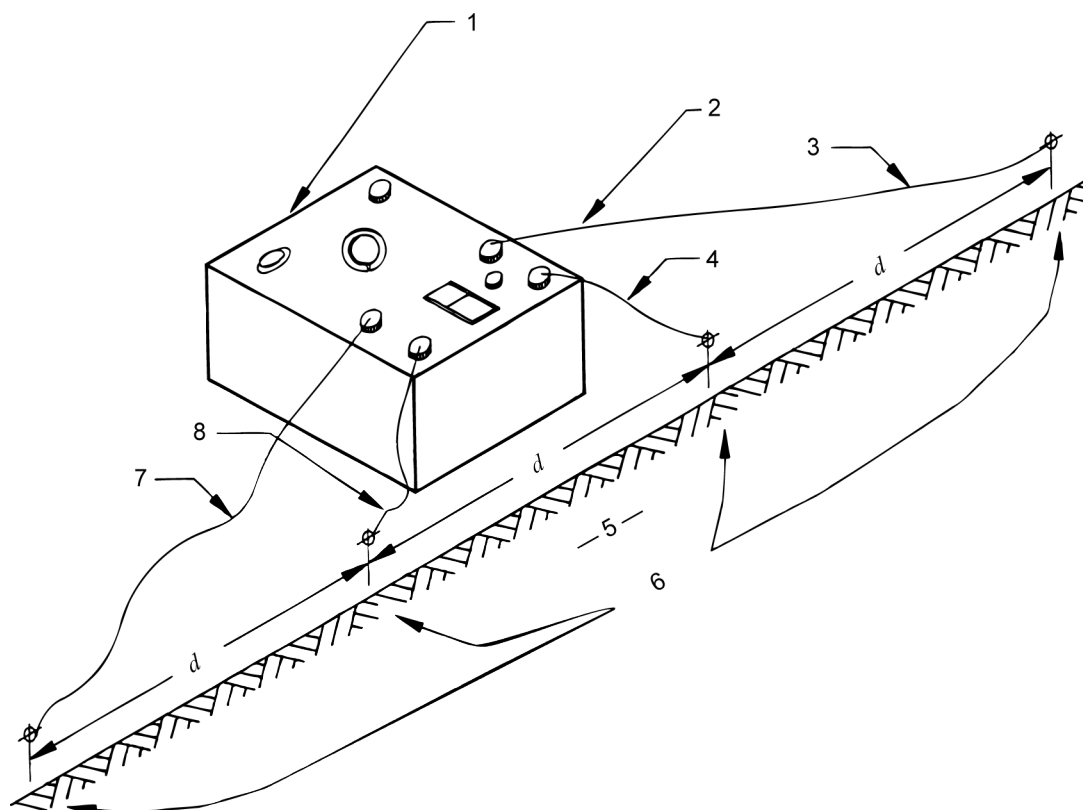

Key

- 1 Four-pin soil resistivity meter
- 2 insulated meter leads
- 3 C-2 lead
- 4 P-2 lead
- 5 soil
- 6 steel pins
- 7 C-1 lead
- 8 P-1 lead

NOTES

$p = \text{"(rho)"};$

= soil resistivity in OHM-CM (OHM-CM = OHM-centimeters);

$d =$ pin spacing, in feet (ft);

$R =$ meter reading after balancing;

$P = 191.5 \times d \times R.$

Figure 26—Wenner Four-pin Soil Resistivity Test

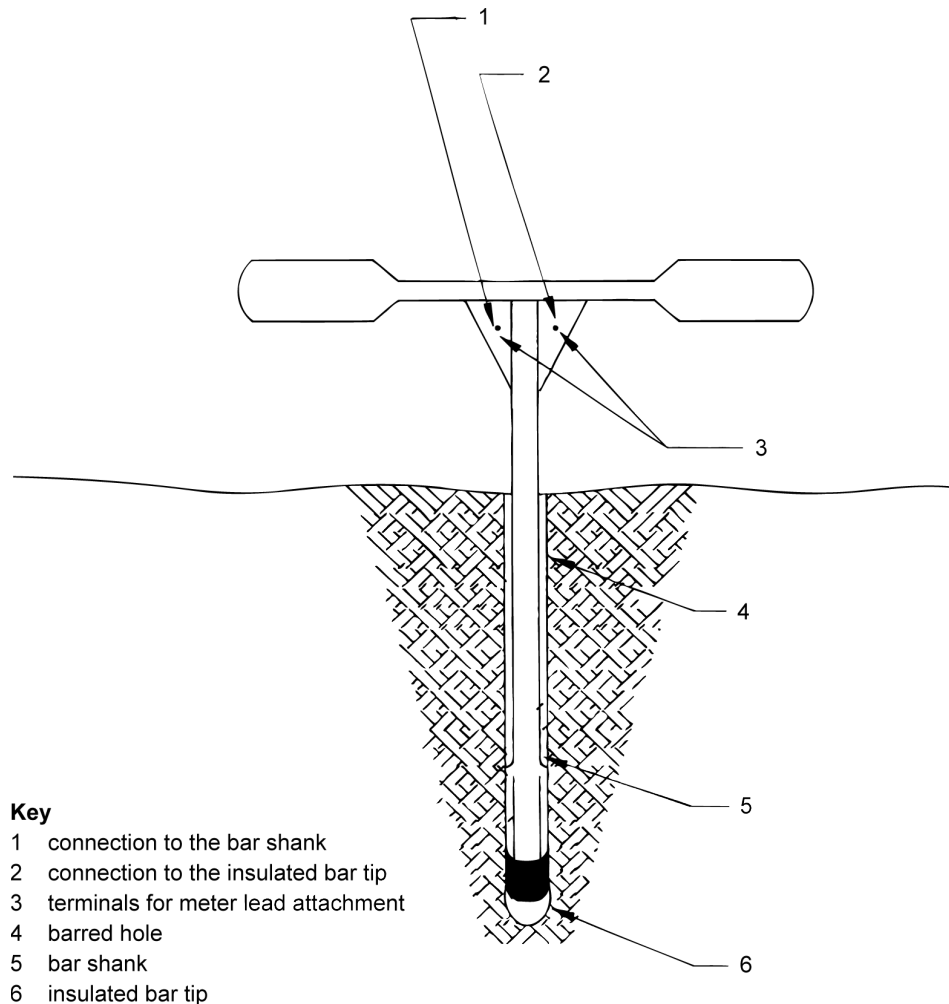
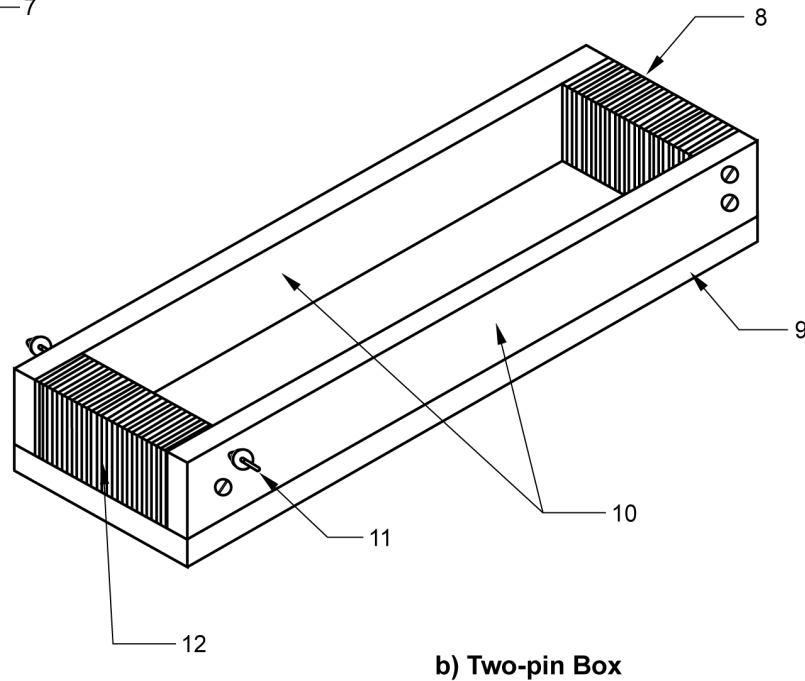
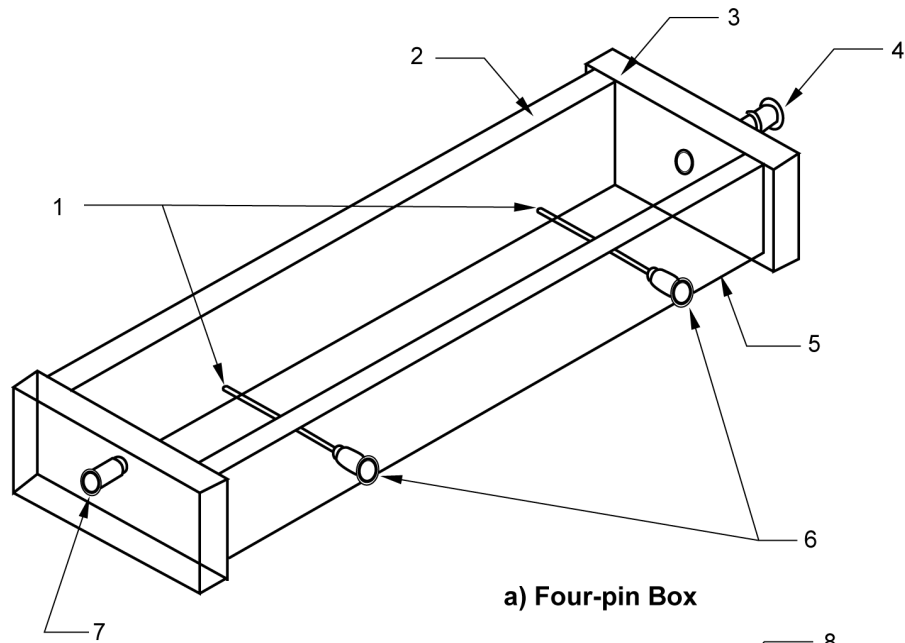

Figure 27—Soil Bar Used for Soil Resistivity Measurements

For measuring the resistivity of soil samples from auger holes or excavations, a soil box serves as a convenient means for obtaining accurate results. The soil box is used to determine the resistivity of soil from a certain location by removing the soil from its location and placing it into a soil box. If the resistivity of the soil sample is not going to be measured immediately after its removal, the soil should be stored in a container that can preserve its moisture and prevent it from contamination. Figure 28 depicts two types of soil boxes used for resistivity measurement. Important points for consideration when using a soil box include the following:

- a) avoiding contamination during soil sample removal, handling, and storing;
- b) avoiding adding or subtracting water;
- c) having to compact the soil sample to the same density in the soil box as it was prior to removal from the ground.

For soil resistivity testing, the depth of piping should be considered in selecting the method to be used as well as the location of the samples. The testing and evaluation of the results should be performed by personnel trained and experienced in soil resistivity testing.



Key

- | | |
|------------------------------|---------------------------------------|
| 1 metal potential pins | 7 current lead attachment |
| 2 plastic | 8 dark plastic box |
| 3 metal | 9 clear plastic box |
| 4 current lead attachment | 10 metal sides |
| 5 plastic | 11 terminal for meter lead attachment |
| 6 potential lead attachments | 12 dark plastic ends |

Figure 28—Two Types of Soil Boxes Used for Soil Resistivity Measurements

7.4.8.5 Cathodic Protection Monitoring

Cathodically protected buried piping should be monitored regularly to ensure adequate levels of protection. Monitoring should include periodic measurement and analysis of pipe-to-soil potentials by personnel trained and experienced in cathodic protection system operation. More frequent monitoring of critical cathodic protection components, such as impressed current rectifiers, is required to ensure reliable system operation.

See NACE SP0169 for guidance on inspecting and maintaining cathodic protection systems for buried piping.

7.4.8.6 Other Inspection Methods for Underground Piping

7.4.8.6.1 General

Several inspection methods are available. Some methods can indicate the external or wall condition of the piping, whereas other methods indicate only the internal condition. Examples are as follows.

7.4.8.6.2 Intelligent Pigging

In-line inspection (ILI) tools are commonly referred to as “smart” or “intelligent pigging.” This method involves the movement of a device (pig) through the piping either while it is in service or after it has been removed from service. Many devices are available employing different methods of inspection utilizing magnetic flux leakage, UT, optical, laser, ET, and other electromagnetic techniques. There are self-propelled ILI or free-swimming tools available that only require one point of access and can perform the wall loss examinations with or without product/fluid in the line. These tools use either ultrasonic or electromagnetic inspection methods to detect and size both ID and OD defects. These tools do not require typical launching and receiving line modifications; however, the use of an umbilical often restricts their inspection range. Beware of potential limitations of ILI on small-diameter piping (i.e. 4” and less) and piping configurations.

7.4.8.6.3 Video Cameras

Video cameras are available that can be inserted into the piping. These cameras can provide visual inspection information on the internal condition of the line.

7.4.8.6.4 Guided Wave Inspection

Guided wave UT can be used to inspect underground piping for internal and external corrosion. Guided waves are sent axially along the piping under examination. Localized wall loss due to corrosion may be located by analyzing the signals of the reflected waves. The techniques require some access to the outside surface for mounting the guided wave transducers. The distance that the waves can travel and provide echoes of sufficient amplitude for analysis depends on many factors, including type and condition of coating on the pipe surface, surface roughness due to internal and/or external corrosion, bonding between pipe and concrete at the air-to-concrete interface, condition of the soil in tight contact with the piping, and fittings on the piping.

7.4.8.6.5 Excavation

In many cases, the only available inspection method that can be performed is unearthing the piping. This is done to visually inspect the external condition of the piping and to evaluate its thickness and internal condition (using the methods discussed in 7.4.8.2).

Care should be exercised in removing soil from above and around the piping to prevent damaging the line or line coating, especially if the piping is in service. The last few inches of soil should be removed manually to avoid this possibility. If the excavation is sufficiently deep, the sides of the trench should be properly shored to prevent their collapse, in accordance with OSHA regulations, where applicable.

If the coating or wrapping is deteriorated or damaged, it should be removed in that area to inspect the condition of the underlying metal.

See 7.4.3 for inspection of the SAI of buried piping.

7.4.8.6.6 Leak Testing

Underground lines that cannot be visually inspected should be periodically tested for leaks. Several methods are available to achieve this objective.

- a) Pressure decay methods involve pressurizing the line to a desired amount, blocking it in, and then removing the source of pressure. Monitoring the line pressure over a period of time will provide an indication of system tightness. Tests may be conducted at a single pressure or multiple pressures. Testing at multiple pressures provides a means of compensating for temperature variations and may enable shorter test times compared to a single pressure test. For pressure decay methods, temperature variation and line pack (e.g. air pockets in a liquid-filled line) can affect the interpretation of results. If desired, the performance of pressure decay methods can be confirmed by leak simulation.
- b) Volume-in/volume-out methods make use of volumetric measuring meters at each end of the line. Typically, these devices are permanently installed in situations requiring custody transfer and/or on-demand leak detection. A standard system would not be able to detect a leak under static (no flow) conditions. If desired, the performance of volume-in/volume-out methods can be determined by a leak simulation.
- c) Single-point volumetric methods are similar to pressure decay measurements requiring the line to be blocked in for a static test. A graduated cylinder is attached to the line to measure volume changes over time. Air pockets in a liquid-filled line and temperature variation can affect the results. Again, the performance of single-point volumetric methods can be determined by a leak simulation.
- d) A marker chemical (i.e. tracer) can be added to the line as a leak detection method. Soil gas samples near the line are collected and tested for the presence of the marker chemical. The absence of any marker chemical in the soil gas samples indicates that the line is not leaking. Supplementary tests are usually required to determine the speed of sample probes in the soil and the speed at which the marker chemical travels through the backfill. Chemical tracers may be added to a liquid- or gas-filled line. This technology has the capability to both detect and locate leaks. The supplementary tests are equivalent to confirming technology performance with leak simulations.
- e) Acoustic emission technology detects and locates leaks by the sound created by the leak. Sensors should be spaced to allow the sound generated by a leak to be detected at the sensor locations. Sensors are attached directly to the pipe so it may require the removal of any protective coating. It should be confirmed that the probable leak conditions will generate sufficient sound to be detected by the sensors. Since geometry and backfill will affect the noise generation, generalized leak simulations may not confirm technology performance.

7.4.8.6.7 Nonintrusive Magnetic and Electromagnetic Techniques

Large standoff magnetic and electromagnetic techniques are available for the screening inspection of buried piping to detect corrosion wall loss and potentially other harmful flaws. These techniques rely on measuring the local magnetic field change due to the presence of wall loss. The inspection can be done without excavation. Differentiating wall loss signals from other magnetic anomalies, such as adjacent piping is a challenge. Follow-up examinations by other methods are also needed to accurately determine the depth of detected wall loss.

Owner-operators should perform structured validation and calibration testing of these technologies prior to their application. This testing is critical, particularly applying these techniques to underground piping within a plant environment.

7.5 Inspection Guidance for Specific Damage Mechanisms

7.5.1 CUI

7.5.1.1 General

A piping inspection program should provide for the external inspection of insulated piping systems. This should include a review of the insulation system integrity for conditions that could lead to CUI, as well as signs of ongoing CUI. API 570 documents the requirements of a CUI inspection program. This section provides guidelines for identifying potential CUI areas for inspection.

CUI occurs due to moisture collecting under the insulation, next to the pipe material. Sources of moisture can include rain, water leaks, condensation, deluge systems, and cooling towers. There are two forms of CUI: localized corrosion of carbon steel and ECSCC of austenitic stainless steel. See API 571 and API 583 for additional details on CUI mechanisms and inspection. See NACE SP0198 for guidance on the use of protective coatings to mitigate corrosion under thermal insulation and fireproofing materials.

This section provides guidelines for identifying potential CUI areas for inspection. The extent of a CUI inspection program may vary depending on the local climate. Marine locations in warmer areas may require a very active program, whereas cooler, drier, mid-continent locations may not need as extensive a program.

7.5.1.2 Insulated Carbon and Low-alloy Piping Systems Susceptible to CUI

CUI can occur in insulated carbon steel and low-alloy carbon steel (referred to collectively as “carbon steel” in this section) piping systems, including ones insulated for personnel protection, operating between 10 °F (−12 °C) and 350 °F (175 °C). CUI is particularly aggressive where operating temperatures cause frequent or continuous condensation and re-evaporation of atmospheric moisture. Carbon steel piping systems, operating above 350 °F (175 °C), are generally not susceptible to CUI, except when:

- a) they are in intermittent service (cyclic service for temperature);
- b) there are deadlegs and attachments that protrude from insulated piping and may operate within the susceptible temperature range for CUI (as stated above).

7.5.1.3 Insulated Austenitic and Duplex Stainless Steel Piping Systems Susceptible to ECSCC under Insulation

In austenitic stainless steels, CUI damage takes the form of ECSCC. Most CUI damage in austenitic stainless steels occurs at metal temperatures between 140 °F (60 °C) and 350 °F (175 °C), although exceptions have been reported at lower temperatures. Austenitic stainless steel piping that normally operates above 500 °F (260 °C) can suffer from ECSCC during start-up after insulation gets soaked from deluge system testing, fire water, or rain during downtime.

NOTE ECSCC of duplex stainless steels does not typically occur until about 285 °F (140 °C) and at very high chloride concentration levels.

Stainless steel piping systems may still be vulnerable to damage when in they are in intermittent service or in cases where there are deadlegs and attachments that protrude from insulated piping and may operate within the susceptible temperature range for CUI damage.

It has been noted that for austenitic stainless steel an aluminum foil wrapping is effective in protecting the surface from ECSCC.

7.5.1.4 Typical Locations on Piping Circuits Susceptible to CUI

Locations of carbon steel and austenitic/duplex stainless steel piping systems exposed or subject to certain conditions can potentially be more susceptible to CUI. These conditions include those:

- a) exposed to mist overspray from cooling water towers;
- b) exposed to steam vents;
- c) exposed to deluge systems;
- d) exposed to condensation dripping from above;
- e) exposed to process spills or ingress of moisture or acid vapors;
- f) subjected to vibration that have a tendency to inflict damage to insulation jacketing providing a path for water ingress;
- g) exposed to moisture from steam-tracing leaks, especially at tubing fittings beneath the insulation;
- h) unmaintained with deteriorated insulation, coatings, and/or wrappings;

NOTE Bulges or staining of the insulation or jacketing system or missing bands are visual indications of deteriorated insulation (bulges can indicate corrosion product buildup).

- i) subject to potential physical damage of the coating or insulation, thereby exposing the piping to the environment.

In addition to the conditions noted above, some specific locations associated with the insulation system design and maintenance can be more susceptible to CUI. These locations include the following:

- a) all penetrations or breaches in the insulation jacketing systems, such as the following:
 - 1) deadlegs (vents, drains, etc.);
 - 2) pipe hangers and other supports;
 - 3) valves and fittings (irregular insulation surfaces);
 - 4) bolt-on pipe shoes;
 - 5) steam and electric tracer tubing penetrations;
- b) termination of insulation at flanges and other piping components;
- c) insulation jacketing seams located on the top of horizontal piping or improperly lapped or sealed insulation jacketing;
- d) termination of insulation in a vertical pipe;
- e) caulking that has hardened, separated, or is missing;
- f) low points in piping systems, particularly ones that have a known breach in the insulation system, including low points in long unsupported piping runs and vertical to horizontal transitions;
- g) carbon or low-alloy steel flanges, bolting, and other components under insulation in high-alloy piping systems.

Particular attention should be given to locations where insulation plugs have been removed to permit piping thickness measurements on insulated piping. These plugs should be replaced and sealed after inspection or maintenance activities. Several types of removable plugs are commercially available that permit inspection and identification of inspection points for future reference.

7.5.2 Erosion and Erosion-corrosion

Erosion can be defined as the removal of surface material by the action of numerous individual impacts of solid or liquid particles or cavitation. It can be characterized by grooves, rounded holes, waves, and valleys in a directional pattern. Erosion is usually in areas of turbulent flow such as at changes of direction in a piping system or downstream of control valves where vaporization can take place. Erosion damage is usually increased in streams with large quantities of solid or liquid particles and high velocities. A combination of corrosion and erosion (erosion-corrosion) results in significantly greater metal loss than can be expected from corrosion or erosion alone.

This type of corrosion occurs at high-velocity and high-turbulence areas. Examples of places to inspect include the following:

- a) downstream of control valves, especially where flashing or cavitation is occurring;
- b) downstream of orifices;
- c) downstream of pump discharges;
- d) at any point of flow direction change, such as the outside radii of elbows;
- e) downstream of piping configurations (welds, thermowells, flanges, etc.) that produce turbulence, particularly in velocity-sensitive systems, such as ammonium hydrosulfide and sulfuric acid systems.

Areas suspected to have localized erosion-corrosion should be inspected using appropriate NDE methods that will yield thickness data over a wide area, such as UT scanning and profile RT.

See API 571 for additional information on erosion and erosion-corrosion.

7.5.3 Environmental Cracking

Piping system materials of construction are normally selected to resist the various forms of SCC. Some piping systems can be susceptible to environmental cracking due to upset process conditions, CUI, unanticipated condensation, or exposure to wet hydrogen sulfide or carbonates. Examples of this include the following:

- a) ECSCC of austenitic stainless steels resulting from moisture and chlorides under insulation, under deposits, under gaskets, or in crevices (see API 583); this is an especially aggressive form of cracking if environmental conditions cause drying and wetting (i.e. the chlorides concentrate); note that CSCC of austenitic stainless steels can also occur internally where chlorides are present with water;
- b) polythionic acid SCC of sensitized austenitic stainless steels and alloys resulting from exposure to sulfide/moisture condensation/oxygen;
- c) caustic SCC (sometimes known as caustic embrittlement);
- d) amine SCC in non-stress-relieved piping systems;
- e) carbonate SCC in alkaline systems;
- f) wet hydrogen sulfide stress cracking and hydrogen blistering in systems containing sour water;
- g) hydrogen blistering and hydrogen-induced cracking damage.

NOTE This has not been as serious of a problem for piping as it has been for pressure vessels. It is listed here because it is considered to be environmental cracking and can occur in piping although it has not been extensive. One exception where this type of damage has been a problem is longitudinally welded pipe fabricated from plate materials.

See API 571 for additional details on environmental cracking mechanisms.

When the inspector suspects or is advised that specific circuits may be susceptible to environmental cracking, he or she should schedule supplemental inspections. Such inspections can take the form of surface NDE (PT or wet fluorescent magnetic particle examination technique), UT, or eddy current technique (ET). Where available, suspect spools may be removed from the piping system and split open for internal surface examination.

If environmental cracking is detected during the internal inspection of a pressure vessel and the piping is considered equally susceptible, the inspector should designate the appropriate piping spools upstream and downstream of the pressure vessel for an environmental cracking inspection.

When the potential for environmental cracking is suspected in piping circuits, an inspection of selected spools should be scheduled before an upcoming turnaround. Such inspection should provide information useful in forecasting turnaround maintenance.

7.5.4 Corrosion beneath Linings and Deposits

If external or internal coatings, refractory linings, and corrosion-resistant linings are in good condition and there is no reason to suspect a deteriorated condition behind them, it is usually not necessary to remove them for inspection of the piping system.

The effectiveness of corrosion-resistant linings is greatly reduced due to breaks or holes in the lining. The linings should be visually inspected for separation, breaks, holes, and blisters. If any of these conditions are noted, it may be necessary to remove portions of the internal lining to investigate the effectiveness of the lining and the condition of the metal piping beneath the lining. Alternatively, UT from the external surface can be used to measure the base metal thickness. When the lining is metallic and is designed to be fully bonded, external UT can also be used to detect separation, holes, and blisters. When damage to the lining has been found or caused through the removal for inspection access, the inspector should note the type and extent of damage and provide a recommendation for repair/replacement if required.

Refractory linings used to insulate the pipe wall can spall or crack in service, causing hot spots that expose the metal to oxidation and creep cracking. Periodic temperature monitoring via visual, infrared, and temperature-indicating paints should be undertaken on these types of lines to confirm the integrity of the lining. Corrosion beneath refractory linings can result in separation and bulging of the refractory. Microwave examination technique (MW) can examine the refractory for volumetric flaws and separation from the shell surface. If bulging or separation of the refractory lining is detected, portions of the refractory may be removed to permit inspection of the piping beneath the refractory. Otherwise, thickness measurements utilizing UT or profile RT may be obtained from the external metal surface. In addition, if external mechanical damage is identified on the pipe, such as a dent, this could be a location where the internal refractory lining may have been damaged too. When damage to the refractory has been found or caused through the removal for inspection access, the inspector should note the type and extent of damage and provide a recommendation for repair/replacement if required.

Where operating deposits, such as coke are present on the internal pipe surface, NDE techniques employed from the outside of the pipe, such as profile RT, UT, and/or ET, should be used to determine whether such deposits have active corrosion beneath them.

7.5.5 Fatigue Cracking

Fatigue cracking of piping systems can result from excessive cyclic stresses that are often well below the static yield strength of the material. The cyclic stresses can be imposed by pressure, mechanical, or thermal means and can result in low-cycle or high-cycle fatigue. The onset of low-cycle fatigue cracking is often directly related to the number of heat-up/cooldown cycles experienced. For example:

- a) trunnions or other attachments that extend beyond the pipe insulation can act as a cooling fin that sets up a situation favorable to thermal fatigue cracking on the hot pipe;
- b) thermal fatigue can also occur at mixing points when process streams at different operating temperatures combine.
- c) excessive piping system vibration (e.g. machine or flow induced) can also cause high-cycle fatigue damage.

See API 570—Section 5.5.6, for vibrating piping surveillance requirements, and API 570—Section 7.8, for design requirements associated with vibrating piping.

Fatigue cracking can typically be first detected at points of high-stress intensification, such as branch connections. Locations where metals having different coefficients of thermal expansion are joined by welding can be susceptible to thermal fatigue. Preferred NDE methods of detecting fatigue cracking include PT, MT, and angle beam UT when inspecting from the OD for ID cracking. Suggested locations for UT on elbows would include the 3 o'clock and 9 o'clock positions. Acoustic emission examination technique (AE) also may be used to detect the presence of cracks that are activated by test pressures or stresses generated during the test. See API 570—Section 6.6.4 for fatigue considerations relative to threaded connections.

It is important for the owner-operator and the inspector to understand that fatigue cracking is likely to cause piping failure before detection with any NDE methods. Of the fatigue cycles required to produce failure, the vast majority are required to initiate cracking and relatively few cycles are required to propagate the crack to failure. As such, proper design and installation to prevent fatigue cracking are important.

See API 571 for additional information on thermal fatigue, mechanical fatigue, and vibration-induced fatigue.

7.5.6 Creep Cracking

Creep damage is dependent on the material of construction, time, temperature, and stress. Creep cracking can eventually occur at design conditions since some piping code allowable stresses are in the creep range. Cracking is accelerated by creep/fatigue interaction when operating conditions in the creep range are cyclic. Particular attention should be given to areas of high-stress concentration. If excessive temperatures are encountered, mechanical property and microstructural changes in metals can also take place, which can permanently weaken equipment. An example of where creep cracking has been experienced in the industry is in 1-1/4 Cr -1/2 Mo steels above 900 °F (482 °C).

NDE methods of detecting creep cracking include PT, MT, UT, RT, and ET. Alternating current field measurement (ACFM), in situ metallography, and dimensional verification (i.e. strapping pipe diameter) are other common practices that may be used for detection. NDE volumetric examination methods, including profile RT and UT, can be used for the detection of creep cracking.

AE can be utilized to identify active creep cracking. The examination can be conducted while piping is in or out of operation. When the examination is conducted, the probability of detecting creep cracks can be a function of crack orientation. Any piping examined out of operation requires a pressure stimulus to activate any damage present.

See API 571 for additional information on creep and stress rupture.

7.5.7 Brittle Fracture

Carbon, low-alloy, and other ferritic steels can be susceptible to brittle failure at or below ambient temperatures. In some cases, the refrigerating effect of vaporizing liquids such as ammonia or C₂ or C₃ hydrocarbons can chill the piping and promote brittle fracture in a material that may not otherwise fail. Brittle fracture usually is not a concern with relatively thin-wall piping. Most brittle fractures have occurred on the first application of a particular stress level (i.e. the first hydrotest or overload) unless critical defects are introduced in service. The potential for a brittle failure should be considered when pressure testing or more carefully evaluated when pressure testing equipment pneumatically or when adding any other additional loads. Special attention should be given to low-alloy steels (especially 2¹/₄Cr-1Mo material) because they can be prone to temper embrittlement and to ferritic stainless steels.

A through-wall crack resulting from brittle fracture and causing a leak can be detected with helium leak detection. Alternatively, active cracking in embrittled material can be detected and possibly located with AE.

See API 571 for additional information on brittle fracture. API 579-1/ASME FFS-1—Section 3 provides procedures for the assessment of equipment for resistance to brittle fracture.

7.5.8 Freeze Damage

At subfreezing temperatures, water and aqueous solutions handled in piping systems can freeze and expand. This can cause failure of the pipe because the metal contacts against the expanding aqueous solution causing a burst scenario. After unexpectedly severe freezing weather, it is important to visually check for freeze damage to exposed piping components before the system thaws. If rupture has occurred, leakage can be temporarily prevented by the frozen fluid. Low points, drip legs, and deadlegs of piping systems containing water should be carefully examined for damage.

To prevent freeze damage, precautions need to be taken to drain, purge, or heat trace systems where moisture could collect and unexpectedly freeze during severe or sudden subfreezing temperature excursions. One of the most critical locations for these precautions is the top of the seat of relief valves and pilot-operated relief valves when moisture could be present. Tailpipes on relief valves that discharge to the atmosphere should always have adequate drainage or heat tracing.

7.5.9 Nonmetallic Damage Mechanisms

In many circumstances, the choice of FRP is based on its inherent resistance to damage mechanisms, such as corrosion. However, no material is totally resistant and so there is a potential for in-service damage. OLF 055 has compiled an extensive review of the topic and produced a framework that may be used in risk assessments and in evaluating damage mechanisms.

Typical in-service damage mechanisms found in FRP nonmetallic piping systems are shown in Table 3.

Table 3—Damage Mechanisms Associated with Nonmetallic Piping

Damage	Cause
Flaws originating from poor construction/design	Inadequate thickness in design when piping is buried too deep. Poor joint assembly.
Erosion	High-flow velocities and particle impact can cause erosion at changes in flow direction and restrictions.
Flange cracks	Overstressed bolted joints. High imposed loadings from corrosion deposits buildup.
Chalking	UV damage when FRP material is exposed to solar radiation without the use of an outer UV light barrier.
Material aging	Breakdown of resin or fiber strength over extended periods of time. The breakdown can be accelerated by exposure to some chemicals, especially strong alkalines.
Deformation	Change in dimensions due to long-term exposure to stress—often described as creep.
Pit/pinhole	Small craters in the surface of the laminate from incomplete resin fill.
Softening	Reduction in hardness associated with moisture ingress when the resin has excessive voids.
Creep	Permanent deflection of the material under long-term stress and temperature. Creep properties are dependent on the resin properties.
Star craze	Sharp impact to the external surface.
Blisters	Permeation of the service fluid into the laminate (common in hydrochloric acid service).
Liner cracking/mud cracking	Chemical degradation, thermal shock, or temperature excursions.

MTI Project 129-99 is a good guide for identifying some of these failure mechanisms.

7.6 Reviewing and Updating Inspection Plans (Future Content)

7.7 IOWs

The use of well-defined, communicated, and properly controlled IOWs for key process parameters (both physical and chemical) that could impact piping integrity if not properly controlled reinforces inspection plans. Examples of the process parameters include temperatures, pressures, fluid velocities, pH, flow rates, chemical or water injection rates, levels of corrosive constituents, chemical composition, etc. Key process parameters for IOWs containing upper and lower limits can be established, as needed, and deviations outside these limits brought to the attention of inspection/engineering personnel. After review of these deviations, a new or adjusted inspection or monitoring plan can be implemented, if required. The review may also require a recommendation for repair/replacement due to life cycle constraints or expected cumulative damage. Particular attention to monitoring IOWs should also be provided during start-ups, shutdowns, and significant process upsets.

Refer to API 584 for more information on IOWs.

7.8 Inspection of New Fabrication

7.8.1 New Fabrication

New piping fabrication should meet the principles of ASME B31.3, ASME B31.1, or equivalent pipe fabrication standard published by standards development organizations.

New fabrication inspection can include the following activities: obtaining initial pipe wall thicknesses at designated CMLs; inspection for cracks; inspection of flange gasket seating faces, valves, and joints; inspection for the misalignment of piping; inspection of welds; and pressure testing.

Existing connecting systems may require checks to determine whether rerating is necessary to meet the specified conditions.

The extent of inspection during fabrication and installation depends largely on the severity of the service and the quality of the workmanship, and it should be part of the inspection test plan.

Examination of welds by RT or other special techniques is typically governed by the fabrication code of construction. A representative number of welds is checked for quality and may also involve hardness testing of the weld and heat-affected zone. PT or MT can reveal cracks and surface defects. Similar techniques can be used to check for defects in castings and in machined surfaces, such as gasket facings.

7.8.2 Material Verification

Both materials and fabrication should be checked for conformance with the codes and specifications that are appropriate for the plant. Some piping items, such as those used in steam generation, can be subject to additional regulatory requirements. Although the piping, valves, and fittings should be specified in detail when orders are placed for new construction, there should be a positive means of identifying the materials installed in the intended piping systems, including weld filler metals. Checks should be made using material test kits or other positive identification means, such as portable X-ray fluorescence or portable optical emission spectrometry analyzers. In addition, manufacturers' material and test data can be obtained for review, particularly when special quality requirements are specified.

Piping material selection should be based on service conditions and experience with piping in the same or similar service. The risk associated with the substitution of wrong materials should determine the extent of PMI of new fabrication, repairs, or alterations.

See API 578 for additional guidance on material verification.

7.8.3 Deviations

Exceptions to specifications or standards for materials, tolerances, or workmanship are usually evaluated based on their effects on factors such as safety, strength, corrosion resistance, and serviceability. Special reviews may be required to determine whether piping items deviate to an extent that necessitates rejection and/or repairs. Risk analysis may be useful in these reviews. Any exceptions that have been accepted should be properly recorded and identified for future reference.

7.9 Newly Commissioned Piping Inspection (Future Content)

8 Strategies for Establishing Frequency of Inspection

8.1 Fixed Interval

The frequency and extent of piping inspections will range from often and extensive in piping classes where deterioration is extreme or high consequence to seldom and cursory in piping classes in noncorrosive or low-consequence services. The frequency of piping inspections should be determined by the following conditions:

- a) consequence of a failure (piping classification);
- b) degree of risk (likelihood and consequence of a failure);
- c) amount of corrosion allowance remaining;
- d) available historical data;
- e) regulatory requirements.

API 570 requires classifying piping systems according to the consequences of failure unless RBI is used to determine piping inspection plans. Each owner-operator should review its piping systems and develop either a classification system using the information provided in API 570 or from an RBI analysis (similar to the elements in API 580 and the methodology in API 581). Either system helps establish minimum inspection frequencies for each piping classification; some inspections can and should be made while the piping is operating. Inspections that cannot be made during operation should be made while the piping is not in service. Elevated operating temperature can limit the inspections techniques that can be effectively used during operation.

8.2 RBI

RBI creates inspection plans based on an assessment of the likelihood of failure and the consequence of failure of a piping system or circuit. RBI may be used to determine inspection intervals or due dates and the type and extent of future inspection/examinations. For more information regarding RBI, the following references may be used:

- a) API 580, for establishing an RBI program, including selection of methodology and sustainability of effort;
- b) API 581, for an example of an RBI methodology for evaluating probability, consequence, and risk, as well as inspection planning based on those results.

Identifying and evaluating credible damage mechanisms, current piping conditions, and the effectiveness of past inspections are important steps in assessing the likelihood of a piping failure. The likelihood assessment should consider all forms of damage that could reasonably be expected to affect piping circuits in any particular service. Examples of those damage mechanisms include internal or external metal loss from an identified form of corrosion (localized or general), all forms of cracking, including hydrogen-assisted

and SCC (from the inside or outside surfaces of piping), and any other forms of metallurgical, corrosion, or mechanical damage, such as fatigue, embrittlement, creep, etc. See API 571 for details of common damage mechanisms.

Identifying and evaluating the process fluid(s), potential injuries, environmental damage, unit piping and equipment damage, and unit loss of production are important aspects in assessing the consequences associated with a failure of the piping.

Any RBI assessment should be thoroughly documented in accordance with API 580, defining all the factors contributing to both the probability and consequence of a failure of the piping system.

After an RBI assessment is conducted, the results may be used to establish the inspection plan and better define the following:

- a) the most appropriate inspection and NDE methods, tools, and techniques;
- b) the extent of NDE (e.g. percentage of piping to examine);
- c) the date for internal, external, and on-stream inspections;
- d) the need for pressure testing after damage has occurred or after repairs/alterations have been completed;
- e) the prevention and mitigation steps to reduce the probability and consequence of a piping failure (e.g. repairs, process changes, inhibitors, etc.).

8.3 Opportunities for Inspection (Future Content)

8.3.1 Scheduled Shutdowns (Future Content)

8.3.2 Unscheduled Shutdowns (Future Content)

8.4 On-stream Inspection

8.4.1 Technical Reasons for Inspecting On-stream

Certain kinds of external inspections should be done while the piping is operating. Vibration and swaying are evident with process flow through the pipe. The proper position and function of supports, hangers, and anchors are most apparent while piping is in operation at temperature. The inspector should look for distortion, settlement, or foundation movement, which could indicate improper design or fabrication. Pipe rollers and slide plates should be checked to ensure that they operate freely.

Leakage is often more obvious during operation. Inspectors should look for signs of leakage both coming from each pipe and onto each pipe. The leakage from a pipe can indicate a hole in the pipe, and leakage onto a pipe can indicate a leak from an unobserved source (e.g. beneath insulation).

Thermal imaging should be done under operating conditions. For example, thermal imaging:

- a) can show pluggage and/or maldistribution of flow that can affect corrosion mechanisms;
- b) can show wet insulation that can lead to CUI;
- c) can show a breakdown of internal insulating refractory, which can lead to high-temperature corrosion of the pipe wall;
- d) may show malfunctions of heat tracing, which could allow unexpected damage mechanisms to operate; for instance, tracing that is too hot may cause caustic SCC of carbon steel carrying caustic solutions, and tracing that is too cold may allow dew-point corrosion.

RT can be as effective during operation as when the piping is offline. On-stream RT could detect fouling that might be washed out of piping during unit entry preparation.

8.4.2 Practical Reasons for Inspecting On-stream

On-stream inspection can increase unit run lengths by giving assurance that piping is fit for continued service.

When piping must be replaced, on-stream inspection allows an inspector to define the extent of replacement necessary and have replacement piping fabricated before the shutdown.

Units are often crowded during a shutdown, and on-stream piping inspection can increase the safety and efficiency of shutdown operations by reducing the number of people who need to be in the unit during that time.

On-stream inspection can reduce surges in work load and thus stabilize personnel requirements.

8.5 Offline Inspection

A common limitation to on-stream inspection is temperature. The equipment used in some kinds of techniques cannot operate at temperatures much above ambient. In addition, the radiant heat from some piping can be too great for technicians to make measurements safely. In both instances, a piping inspection may need to be done when the piping is not in operation.

Signs of wet insulation should be noted when piping is offline. Water dripping onto insulation may not show dampness during operation because heat from the pipe causes surface water to evaporate, but water deeper in the insulation can still cause CUI. If dampness is noted during a shutdown, the damp piping should be considered for CUI inspection.

When piping is opened for any reason, it should be inspected internally as far as accessibility permits. Some piping is large enough for internal inspection, which can only occur while the piping is offline.

Adequate follow-up inspections should be conducted to determine the causes of defects, such as leaks, misalignment, vibration, and swaying, that were detected while the unit was operating.

8.6 Inspection Scope

Piping inspection should be frequent enough to ensure that all piping has sufficient thickness to provide both pressure containment and mechanical support. For pipes undergoing uniform corrosion, calculating the corrosion rate and remaining life at each CML and then setting the inspection interval based on the half-life has traditionally provided that assurance. The inspector, often in consultation with corrosion specialists and piping engineers, determines the number and locations of CMLs (see API 570). RBI may be used to determine interval or due date and extent.

For damage mechanisms other than uniform corrosion, the inspector should determine the type of inspection, the frequency, the extent, and the locations of CMLs. Corrosion specialists and piping engineers have typically helped in this process as well.

9 Safety Precautions and Preparatory Work

9.1 Safety Precautions

9.1.1 General

Safety precautions should be taken before any inspection or examinations are performed. The appropriate personal protective equipment (PPE) should be utilized for each inspection. Procedures for the separation of piping, installation of blinds, and leak testing should be an integral part of safety practices. In general,

the section of piping to be opened should be isolated from all sources of harmful liquids, gases, or vapors and purged to remove all oil and toxic or flammable gases and vapors.

Hammer testing of pressured piping might cause failure and allow the contents of the piping to be released. Precautions should be taken before any hammer testing of in-service piping.

RT must be performed in accordance with the applicable requirements of the site and jurisdiction due to potential radiation exposure.

Caution should be taken when attempting to remove scale and deposits from the external surfaces of in-service piping, especially when operating at high pressure or at temperature when the piping contains hazardous/flammable process fluids. Loss of containment incidents have occurred when deposits were removed while inspecting for CUI, support point corrosion, cooling water drift corrosion, etc. that were covering through-wall corrosion damage. The owner-operator may consider the following to mitigate the risk of a through-wall event:

- a) use of profile RT or UT NDE to inspect under deposits and determine the amount of corrosion damage, before disturbing the deposits;
- b) develop an emergency response plan in the event that a through-wall leak develops; this plan should include provisions to isolate the affected area, temporary repair provisions, and any additional PPE requirements.

9.1.2 Precautions Regarding the Use of Breathing Air (Future Content)

9.1.3 Precaution Regarding Confined Space Entry (Future Content)

9.2 Communication

Before starting any piping system inspection and/or maintenance activities (e.g. NDE, pressure testing, repair, or alteration), personnel should obtain permission from operating personnel responsible for the piping to work in the vicinity.

When individuals are inside large piping systems, all persons working around the equipment should be informed that people are working inside the piping. Individuals working inside the piping should be informed when any work is going to be done on the exterior of the piping.

9.3 Preparatory Work

All possible preparatory work should be done before the scheduled start of the inspection. Scaffolds should be erected, insulation removed, and surface preparation completed where required. Buried piping should be excavated at the points to be inspected. Equipment required for personal safety should be checked to determine its availability and condition. Any necessary warning signs should be obtained in advance, and barricades should be erected around all excavations. The appropriate signs and barricades, as required by the site and jurisdiction, should be in place before RT is performed.

All tools, equipment, and PPE used during piping work (i.e. inspection, NDE, pressure testing, repairs, and alterations) should be checked for damage and/or operability prior to use. NDE equipment and the repair organization's equipment are subject to the owner-operator's safety requirements for electrical equipment. Other equipment that might be needed for piping system access (e.g. planking, scaffolding, and portable ladders) should be checked for adequacy and safety before being used.

During the preparation of piping systems for inspection, PPE should be worn when required either by regulations, the owner-operator, or the repair organization.

The tools needed for inspection should be checked for availability, proper working condition, calibration, and accuracy. The following tools and instruments are often used in the inspection of piping:

- a) ACFM crack detection equipment;
- b) alloy analyzer (nuclear source for material identification);
- c) borescope and/or fiberoptic;
- d) camera;
- e) crayon or marker;
- f) direct-reading calipers with specially shaped legs;
- g) eddy current equipment;
- h) flashlight and additional portable lighting;
- i) hammer;
- j) ID and OD transfer calipers;
- k) infrared pyrometer and camera;
- l) knife;
- m) leak detector (sonic, gas test, or soap solution);
- n) liquid penetrant equipment;
- o) magnet;
- p) magnetic particle equipment;
- q) magnifying glass;
- r) material identification kit;
- s) microwave inspection equipment;
- t) mirror;
- u) notebook or sketches;
- v) paint;
- w) pit-depth gauge;
- x) portable hardness tester;
- y) radiographic equipment;
- z) remote television camera (for internal inspection);
- aa) scraper;
- ab) steel rule;
- ac) thickness or hook gauge;
- ad) ultrasonic equipment;
- ae) wire brush.

In addition to the list above, grit blasting or comparable equipment may be required to remove paint and other protective coatings, dirt, or corrosion products so that the surface is properly prepared for the inspection technique (e.g. inspection for cracks with MT).

9.4 Cleaning and Surface Preparation for Inspection (Future Content)

9.5 Investigation of Active Leaks

On-stream piping leaks in process units can occur for various reasons. Those who investigate the leak may be particularly at risk to the consequence associated with the release of the process fluid. A site should create a general safety procedure to be followed during a piping leak investigation. A further precaution is to hold a safety review before any leak investigation. The review would consider the state of a piping system in terms of pressure, temperature, remaining inventory of process fluids, credible damage mechanisms, and similar factors. Where piping can be generally thinned rather than contain isolated defects, potential pipe rupture is more likely and should be taken into consideration when investigating leaks or during firefighting efforts. Reference API 2001 for more information on leak response protocol.

The safety review team should define:

- a) a “hot zone” around the leak site and establish PPE and additional firefighting equipment requirements to perform work inside this zone;
- b) decontamination requirements upon exit from the hot zone and other requirements necessary to protect personnel and the environment.

The safety review team must be careful in making assumptions about the leak’s cause. Incidents have occurred where investigative personnel assumed they knew the cause of a small leak on an operating line and were caught unprepared when the leak suddenly became quite large.

10 Inspection Types, Methods, and Limitations

10.1 External Visual Inspection

10.1.1 General

External visual inspections are performed to determine the external condition of piping, insulation system, painting/coating system, and associated hardware as well as to check for signs of misalignment, vibration, and leakage. Annex A contains a sample checklist for external inspections that should be conducted in accordance with API 570—Section 5.5.5.

10.1.2 Leaks

Leaks can be safety or fire hazards. They can cause a premature shutdown of equipment and often result in economic loss. Leaks in utility piping are seldom hazardous or cause shutdowns, but they do result in loss. Leaks in hot or volatile oil, gas, and chemical piping can result in a fire, an explosion, contamination of the surrounding atmosphere, a serious environmental problem, a premature shutdown, or production loss. Frequent visual surveillance by operators should be made for leaks. Particular attention should be given to flanged joints, packing glands, bonnets of valves, and expansion joints on piping that carries flammable, toxic, corrosive, or other harmful materials. Many leaks can be stopped or minimized by tightening packing glands.

Tightening flange bolts in a pressurized line is only recommended when special steps are taken to avoid three potential problems:

- a) bolt interactions (e.g. when a bolt is tightened the adjacent bolts are loosened);
- b) a bolt can yield or fail due to overloading;
- c) tightening one side of a flange can cause deflections in the areas opposite and adjacent to it.

Leaks of certain fluids can result in the cracking and/or corrosion of flange bolts; in such instances, the bolts should be replaced. The prompt repair of leaks will often prevent serious corrosion or erosion of gasket surfaces or packing glands. Temporary or permanent repairs may be made while lines are in service, but a proper evaluation of the work should be completed.

Wet hydrogen sulfide stress cracking and hydrogen blistering in systems in sour (H_2S laden) service may occur externally if trapped due to a leak that is clamped.

Liquid that has leaked into the ground can usually be located by looking for liquid puddles on the ground or by discoloration of the earth. The liquid spill should be investigated to determine whether the liquid is corrosive to materials of construction that it could come in contact with. This includes pipe material of construction, protective coatings, or any insulation jacketing systems. If the liquid is corrosive to these materials, they may warrant inspection to assess any damage. Determining the composition of the liquid may involve chemical analysis of soil samples or the liquid, unless the source of the leak is known.

10.1.3 Misalignment

Piping should be inspected for misalignment, which can be indicated by the following conditions:

- a) piping dislodged from one or more supports so that its weight is not being properly distributed on the remaining hangers or saddles;
- b) the deformation of a vessel or tank wall in the vicinity of a piping attachment, which may also be the result of thermal expansion in the piping system, major piping misalignment, or inadequate piping support;
- c) piping supports forced out of plumb by expansion or contraction of the piping;
- d) excessive replacement or repair of bearings, impellers, and turbine wheels of centrifugal pumps, compressors, and turbine seals to which piping is connected;
- e) the shifting of a base plate, breaking of a foundation, or shearing of foundation bolts of mechanical equipment to which piping is attached;
- f) cracks in connecting flanges or the cases of pumps or turbines to which piping is attached;
- g) expansion joints that are excessively deformed or not performing properly.

If significant piping misalignment is discovered, it should be corrected as determined by damage extent and risk.

10.1.4 Supports

10.1.4.1 General Pipe Support Inspection

Support locations should be identified in appropriate record systems and inspected to verify that the supports are functioning properly and are not causing damage to the pipe.

The prioritization of support inspections may be made on the basis of the likelihood of damage or may be made on the basis of a risk assessment that also considers the consequence of a failure.

Statistical techniques may be used to determine the required inspection sample size to ensure the necessary degree of confidence. Site-specific data related to historical piping support problems should be referenced to better understand the vulnerability of particular support design, location, or application.

Statistical analysis may be used to evaluate the inspection data collected during sampling inspections and determine if additional inspection, up to and including 100 % inspection of particular piping supports and/or designs is warranted. Close visual inspection of piping supports or contact point locations may provide additional data to help determine where more detailed, quantitative techniques are required.

External inspection of supports should include the following examinations where applicable.

- a) Visual examination for general physical damage, distortion, and deterioration of protective coatings or fireproofing.
- b) Visual examination for evidence of corrosion, especially at or near contact points, the foundation attachments, and near dummy legs (trunnions).

Close visual examination of the contact point area between the piping and support can identify corrosion damage by the presence of rust buildup and/or paint blistering and discoloring. However, the severity of corrosion cannot always be assessed without further examination. Highly localized corrosion may be missed as the visual appearance may not be significant. Mirrors provide an advantage when inspecting support locations with limited access.

Dummy leg drain holes should be examined to ensure that they are open and unobstructed. The dummy leg drain holes should not be sitting on any structural supports, which may allow water to wick into any horizontal closed dummy leg. Vertical dummy legs should have a drain hole at the bottom. Water should never be allowed to accumulate within a piping support trunnion.

Lifting pipe from supports or contact points using a crane or other lifting equipment can allow for a more accurate determination of the condition and extent of the damage. Lifting a pipe, which may already have suffered corrosion, can be hazardous and should be carried out with extreme caution. Safety precautions for lifting the pipe will vary depending on the fluid contained, line pressure, anticipated pipe condition, and location on-site/off-site. This should involve a job safety analysis prior to performing the task. In some instances, the pipe lifting may be considered too hazardous for particular fluids (e.g. propane) or particular services if the line cannot be depressurized. If external corrosion is evident, any external cleaning using mechanical means, abrasive blasting, or high-pressure water blasting should be done with extreme caution so as to minimize the chance of prematurely causing a loss of containment event.

Support removal and temporary support placement, when possible, can also be an effective method to gain access and allow for a more thorough examination. When removing support, or using temporary support, the same precautions apply as for lifting pipe.

- c) Visual examination for signs of movement and restricted operation of pipe rollers, slide plates, pulleys, or pivot points in counterbalanced support systems. The inspection should also include a search for small branch connections that are against pipe supports that might be constraining the thermal movement of the larger line.
- d) Visual examination for deterioration of concrete footings, foundations, or plinth blocks. If deterioration of concrete footings is found, the cause should be determined and corrective action should be taken.
- e) Visual examination for failed fireproofing at support locations.
- f) Visual examination for failed or loose foundation anchor bolts. Loose foundation bolts can be found by lightly rapping the bolt sideways with a hammer while holding a finger against the opposite side in contact with the bearing plate. The movement of the bolt will be easily detected. Nuts that move easily when tightening with a wrench may also indicate loosening. Broken bolts can be detected using the same methods used to find loose bolts. Shifting of the bearing plate on its foundation can indicate that the foundation bolts are sheared.

- g) Visual examination for insecure attachment of brackets and beams to the support, or insecure attachment or improper adjustment of pipe hangers.
- h) Visual examination of the spring can integrity and proper operation. For spring supports, the following items need to be inspected for any evidence of corrosion or mechanical overload:
 - 1) spring can;
 - 2) spring;
 - 3) locking device;
 - 4) hanger accessories (rods and support clamps);
 - 5) piping under support clamps;
 - 6) supporting structural steel.

Spring hanger loads should be checked under both cold and hot conditions, and the readings obtained should be checked against the original cold and hot readings. Improper spring support settings can cause excessive pipe loads on rotating equipment that can result in misalignment. Other factors, such as differential settlement and creep, can make alternate settings necessary.

- i) Thickness examination of the process pipe enclosed by dummy leg (trunnion) support attachments for corrosion damage; normally, profile RT is used to determine if corrosion damage exists on the process pipe. In some instances, ultrasonic thickness measurements may be possible. The examination should include the center of the pipe enclosed by the dummy leg (trunnion) support and as near as possible to the interior edge of the weld attachment where water may sit in the dummy leg.

10.1.4.2 Specialized NDE Technique for Contact Points

Several types of specialized NDE techniques may allow inspection of contact points without the lifting of the pipe or removal of the support.

- a) Long-range UT: Ultrasonic Guided Wave Inspection—Low-frequency ultrasonic guided waves can be used for the detection of internal and external corrosion from a single point of access on the pipe to a distance of about 30 m (98 ft) in both directions. The distance and effectiveness may be reduced by factors such as fittings, flanges, heavy external coatings and concrete, and heavy products inside the pipe. This technology cannot differentiate between internal and external corrosion or may not locate the most severe localized corrosion; however, it can be used as a screening tool. When supports are welded to the pipe, the detection of defects is not effective. Highly localized corrosion is not reliably detected with long-range UT.
- b) Electromagnetic Acoustic Transducer (EMAT) Ultrasound—The EMAT system can be used to inspect pipe support locations on live, on-stream process piping. This monitors ultrasonic Lamb wave mode (as well as velocity and amplitude changes) and enables defects at support locations to be detected and sized.

The EMAT system does not require contact or a couplant, and the ultrasonic transducers use magnetic waves and high-current tone bursts to generate Lamb waves. These waves propagate circumferentially around the pipe.

Transducers, housed in a scanner that moves along the pipe, measure the mode and velocity changes of the Lamb waves and convert the output into readings of wall thickness. The accuracy can vary

depending on the defect characteristic and material thickness. The owner-operator should consider validating the performance accuracy.

EMAT can (at the time of document release) be used to survey pipe diameters 4 in. to 24 in. NPS (100 mm to 600 mm NPS).

- c) **Creeping Head Wave Method**—The Creeping Head Wave Method can detect corrosion of a pipe at a distance from the point of access. It requires contact with the pipe in two locations, one at either side of the pipe support (maximum effective span between transducer heads is 3.3 ft. (1 m).

Ultrasonic compression waves are launched along the surface of the pipe and result in the production of shear waves in the body of the material. When the shear waves reach the opposite side of the pipe wall, they convert back to compression surface-skimming waves.

Corrosion and other flaws result in a scattering of surface-skimming waves, and they can therefore be located and sized based on an analysis of the waves.

The presence of too much debris can prevent the technique from being effective.

Creeping Head Wave Method results are usually reported by estimating the defect severity into three ranges that include the following:

- 1) defect of less than 10 % through-wall thickness loss;
- 2) defect of between 10 % and 40 % through-wall thickness loss;
- 3) defect of greater than 40 % through-wall thickness loss.

Creeping Head Wave Method can also be utilized to survey for corrosion between pipe and saddle supports.

- d) **Shear Wave Angle Beam Techniques**— Single or multiple angle shear wave beam techniques may be used to detect and size wall loss at contact point locations. Various techniques exist ranging from single angle-single element to multiple angle-phased array techniques. These angle beam techniques typically rely on an amplitude-based approach to determine wall loss in pulse-echo or pitch-catch configurations. In addition to the wall loss at the contact point area, the shear wave amplitude may be affected by other parameters including general surface condition, coating type and condition, probe wedge contact and coupling, material effects, and other factors. The morphology and extent of corrosion may also influence technique performance. Therefore, all these other parameters should be considered when assessing the accuracy and precision of the NDT technique.

When choosing a special emphasis inspection technique for supports, some techniques such as ultrasonic guided wave and Creeping Head Wave Method may not be effective at detecting localized corrosion areas with near through-wall depths and should not be relied upon to find this type of defect. Other inspection and sampling techniques should be used.

10.1.4.3 Pipe Support Risk Ranking

Risk assessment may be considered to identify vulnerable pipe supports and in deciding where sample inspection may and may not be used. Determination of the most vulnerable areas should consider the following.

- a) Factors affecting the likelihood of damage, including the following.

- 1) Is the support of a type that has a history of giving problems? For example, supports with a flat surface (e.g. open dummy legs, beam supports, saddle clamps, and H beams), provide a crevice for the retention of water, which can promote corrosion.
 - 2) Does the support design promote continuously moist conditions (e.g. contact with insulation)?
 - 3) Is there an effective coating on the pipe in the area of the support?
 - 4) Is the support in an area of the plant that is particularly wet (e.g. near cooling towers)?
 - 5) Is the temperature in the area of contact elevated such that corrosion could be accelerated?
 - 6) Could pipe movement result in distortion or high local stresses on the pipe in the area of the support?
 - 7) How long (i.e. age) has the support been in service?
- b) Factors affecting the consequence of failure, such as health and safety hazards to personnel if leaks occur, the impact on the environment, the unavailability of equipment, and any resultant financial impact.
- c) On-site and off-site areas; there is usually no distinction between on-site and off-site areas in terms of corrosion vulnerability. However, the location can have corrosion-contributing factors, such as flooding or lack of drainage, weeds, mud, etc.

10.1.5 Vibration

Routine operator rounds and external visual inspections that identify loud sounds or visual changes in piping either expected (e.g. slug flow) or unexpected that results in movement, dents, deformations, or changes in support conditions at piping guides, etc. should be reported to the inspector. Such reports should be reviewed with consideration of the potential impact on the integrity of the piping system and if further follow-up should be undertaken (e.g. monitoring, inspection, engineering evaluation, operational change, etc.).

Specific observation rounds should be considered after an unexpected process upset, heavy relief incident, or weather event. For example, large diameter thin-wall pipe may be specifically at risk from vortex-induced vibration and movement.

If vibration or swaying is observed, welds should be inspected for cracks, particularly at points of restraint, such as areas where piping is attached to equipment or near anchors. Problems frequently occur at small welded and screwed connections that have a heavy valve that accentuates vibration and at small lines that are tied down to a larger line and forced to move with it. Additional support should be considered for poorly braced small-sized piping and valves and for the main vibrating line to which they are attached. In cases of severe vibration, it may be advisable to have a competent consultant recommend a remedy, particularly if specialized equipment, such as a pulsation bottle or sway stabilizers, may be required.

10.1.6 External Corrosion

Defects in protective coatings or the jacketing of insulation systems will permit moisture to come into contact with the piping. When defects are found in the jacketing of the insulation system, the extent and severity of the corrosion should be determined by either removing insulation or radiographing the affected area. Sections of insulation may be removed from small connections, such as bleed lines and gauge connections, since difficulty in obtaining a good seal in the insulation makes these locations particularly vulnerable to external corrosion. Any time removal of insulation and jacketing is performed to conduct CUI inspection, it is important to repair/replace the removed insulation and jacketing and ensure proper sealing of removed

materials and/or watershedding of the jacketing to prevent further water ingress. See API 583 for further information concerning CUI.

All of these points should be investigated:

- a) lines that sweat are susceptible to deterioration at areas of support;
- b) corrosion can be found under clamps on suspended lines;
- c) piping mounted on rollers or welded support shoes is subject to moisture accumulation with resultant corrosion;
- d) liquid spilled on piping, the impingement of a jet of steam, and water dripping on a line can cause deterioration;
- e) loss of vapor-sealing mastic from the insulation of piping in cold service can result in local corrosion;
- f) pipe walls inside open-ended trunnion supports are subject to corrosion.

A loss in thickness can be determined by comparing the pipe diameter at the corroded area with the original pipe diameter. The depth of pits can be determined with a pit-depth gauge.

Bolting should also be checked, especially in marine environments and other corrosive environments.

10.1.7 Hot Spots

Piping operating at temperatures higher than the design limit or in the creep range, even without higher pressure, can experience bulging. In piping that is protected from excessive temperatures by internal insulating refractory, failure of the refractory will result in overheating of the metal wall, causing a hot spot. Excessive temperature greatly reduces the strength of the metal and can cause bulging, scaling, localized buckling, metal deterioration, or complete failure.

Another potential cause for a hot spot is where refractory-lined pipe becomes externally insulated. This can cause the metal wall temperature to increase potentially approaching the process temperature. One common occurrence creating this situation is when maintenance work is required near or on a refractory-lined pipe and temporary blanket insulation is put on the pipe to prevent workers from being burned or overheated while performing their tasks. In worse situations, the temporary blanket insulation is forgotten and not removed. During external examinations of the refractory-lined pipe, the presence of external insulation should be noted and removed if not per design.

Frequent inspections should be performed to detect hot spots on refractory-lined piping. Any bulging or scaling should be noted for further investigation when the equipment is shut down. Some hot spots can be detected by a red glow, particularly if the inspection is made in the dark. The skin temperature of indicated hot spots should be measured using a portable thermocouple, temperature-indicating crayons, temperature-indicating paints, thermography, or a pyrometer. To ensure that an in-service rupture does not occur, the amount of bulging should not exceed the amount of creep permitted for the material. As an interim measure, cooling severe hot spots with steam, water, or air may be desirable or necessary until the system can be removed from service (this situation should be reviewed by a piping engineer and/or corrosion specialist). The condition of both the pipe metal and the internal insulation near hot spots should be investigated during the next shutdown period.

10.1.8 Extent of CUI Inspection

The intent of the CUI inspection requirements in API 570 is that the first step is a walk-down visual examination of the condition of insulated piping. This may be achieved in several ways either with direct

human visual examination, utilizing cameras on poles, or unmanned aerial systems often referred to as drones. It is important for the inspector to be confident of the inspection coverage that will enable them to make an acceptable judgement in evaluating the observations.

The assessment should include identifying areas where the weather jacket or insulation is damaged, as well as noting the remaining areas where no damage has been revealed. All piping is then evaluated against the guidance in API 570 as to whether it falls in the “susceptible to CUI” temperature ranges and what piping class it has been designated.

After the walkdown, in the case where it has been determined that the pipe is not in the CUI susceptible range and no damage has been observed, then no further inspection is required. In the case where the piping is within the CUI susceptible range, the appropriate inspection planning should be implemented. Table 4 provides suggested guidance for the removal of insulation or application of appropriate NDE techniques that can identify pipe damage through the insulation. For example:

- a) for Class 1 pipe where damage or indication of CUI was found, an inspection plan would be created and performed on 75 % of the identified damage areas;
- b) for Class 1 pipe where no damage has been identified but operates in the CUI susceptible range, the inspection plan would be created and performed on 50 % of the undamaged areas.

Table 4—Table 2 of API 570

Pipe Class	At Damaged Insulation Locations	At Nondamaged Locations (No Visual Damage Identified during Visual Examination)
	Approximate Amount of Examination with NDE or Insulation Removal at Areas with Damaged Insulation	Approximate Amount of CUI Inspection with NDE or Insulation Removal at Areas without Damaged Insulation ^b
1	75 %	50 %
2	50 %	33 %
3	25 %	10 %
4	Optional	Optional

^a Susceptible piping is piping systems operating within the susceptible temperature ranges as indicated in API 583.
^b The third column is additional areas to consider inspecting and not progressive from the second column.

Subsequent inspection may be defined based on the findings from these initial examinations. Where CUI is identified, escalation of inspection may result in 100 % of insulation removal or NDE examination.

Any time removal of insulation and jacketing is performed to conduct CUI inspection, it is important to repair/replace the removed insulation and jacketing and ensure proper sealing of removed materials and/or watershedding of the jacketing to prevent further water ingress.

Refer to API 583 for further information concerning CUI and possible NDE techniques to identify damage.

10.2 Internal Visual Inspection

10.2.1 Corrosion, Erosion, and Fouling

Piping can be opened at various places by removing a valve or fitting or by springing the pipe apart at flanges to permit visual inspection. The internal surfaces of the piping should be inspected visually over the greatest possible area. A flashlight or extension light is usually sufficient for this task, but a probe, such as

a borescope or a mirror and light, will permit a more detailed view. Other inspection methods include optical/laser and mechanical calipers. Internal inspection of process piping should be made at any old to new piping tie-points created during maintenance or project activities.

Where nonuniform corrosion or erosion conditions are noted in areas that are accessible for visual examination, it may be advisable to perform inspection of the areas that are inaccessible. RT or UT thickness measurements can be performed. This allows an extension of inspection coverage and provides a higher degree of confidence in the overall inspection. This applies particularly to piping that could not be or was not inspected during operation. Nonuniform corrosion or erosion can also be pinpointed for closer examination by directing sunlight along the surface of the piping with a mirror or by shining a light parallel to the surface.

The amount of fouling should be noted to determine whether cleaning is necessary. Fouling should be investigated to determine whether it consists of deposits from the product stream or is a buildup of corrosion products. Taking samples for chemical analysis may be necessary.

10.2.2 Cracks

The locations most susceptible to cracking are welds and the heat-affected zones, including fillet welds, at locations other than pressure welds; heat-affected areas adjoining welds; and points of restraint or excessive strain. Other areas prone to cracking are locations that contain crevices, such as socket-welded piping, flange surfaces, or threaded joints. Locations that are subject to SCC, hydrogen attack, and caustic or amine embrittlement also require attention, as do exposed threads of threaded joints.

The inspected surface should be clean if cracks are to be detected. Cleaning can be accomplished by wire brushing, sandblasting, or chemically removing coatings, deposits, and corrosion products. After a thorough cleaning, the area should be visually inspected for any indications of cracks. (Spot checking by MT, PT, or UT should be considered even if the visual inspection revealed no cracks.) Adequate lighting and a good magnifying glass will assist in locating such indications. Visual inspection may not differentiate between a surface scratch and a crack. Any apparent scratch should be further investigated by other methods. MT can be used on magnetic materials. PT and UT can be used on both nonmagnetic and magnetic materials. Only liquid penetrants with low or no chlorides should be used for austenitic materials. Other methods, such as shear- or surface-wave UT, ET, ACFM, or sample removal for microscopic inspection, may be used. The depth of a crack may be determined by NDE or by chipping or grinding until sound metal is reached. However, the inspector should determine if the area can be repaired properly before commencing to grind.

10.2.3 Gasket Faces of Flanges

The gasket seating faces of flanged joints that have been opened should be visually inspected for corrosion and defects, such as scratches, cuts, and gouges that might cause leakage. The gasket faces should be checked for warping by placing a straight edge across the diameter of the face of the flange and rotating it around an axis through the flange centerline. Grooves and rings of ring joints should be checked for defects, including cracks at the bottom of the grooves or on the sealing surfaces.

For HF alkylation services, see specific recommendations in API 751 on inspection for flange face corrosion.

Phased-array UT is a potential method for inspecting for flange face corrosion without having to disassemble flanges.

10.2.4 Valves

Normally, valves used in process piping systems have body thicknesses somewhat heavier than adjoining piping. For this reason, an adequate piping corrosion-monitoring program need not routinely include monitoring of valve body thicknesses. However, in piping circuits where corrosion rate monitoring of piping indicates severe corrosion or erosion, consideration should be given to routinely measuring thicknesses of selected valve bodies in the circuit.

In severe services, such as HF, slurry, and fluidized catalyst services, valves may need to be dismantled and inspected at specified intervals to ensure that the internal parts are of sufficient integrity to provide reliable and safe operation.

Whenever valves are removed from service for overhaul or refurbished for reuse, they should be inspected and tested to the requirements of API 598. When a valve is disassembled for inspection, the bonnet gasket should be replaced. Any valve parts that do not meet the minimum requirements of the applicable valve standard should be either repaired or replaced. The used valves should be restored for continued safe operation. Refer to API 621 for valve reconditioning.

When body thicknesses are measured, the measurements should include locations that were inaccessible before dismantling, particularly in areas that show evidence of corrosion or erosion. Bodies of valves that operate in severe cyclic temperature service should be checked internally for cracks.

Gate valves should be measured for thickness between the seats because turbulence can cause serious deterioration. This is a particularly weak location because of the wedging action of the disc, or wedge, when the valve is closed. The seating surfaces should be visually inspected for defects that might cause leakage. The wedge guides should be inspected for corrosion and erosion, both on the wedge and in the body.

The stem and the threads on the stem and in the bonnet should be examined for corrosion. The connection between the stem and the wedge should be inspected to ensure that the wedge will not detach from the stem during operation.

Swing-check valves can be inspected by removing the cover or cap. Check valves often flutter, making the shaft and hinges the principal points of deterioration. The disc should be checked for free rotation, and the nut holding either to the arm should be checked for security and the presence of a locking pin, lock washer, or tack weld. The arm should be free to swing, and the anchor pin or shaft should be inspected for wear. The seating surfaces on both the disc and the valve body can be checked for deterioration by feeling them with the fingers. It is extremely important that the cover is installed in the proper orientation for the wedge to operate properly. Refer to API 570 for requirements for the inspection of critical check valves.

Quarter-turn valves can be inspected for ease of operation and the ability to open and close completely by operators. When they are serviced, all seating surfaces should be examined.

When valves are reported by operators to have “operability” problems (e.g. leaking through the gate when fully closed), a review of the potential for that leakage to cause or accelerate deterioration downstream of the valve should be conducted. This helps establish the priority for valve replacement and the need of increased inspection of downstream piping.

10.3 Specific Areas or Components for Inspection

10.3.1 Inspection of Piping Welds

API 570 provides a detailed discussion of the inspection of in-service piping welds. In addition, API 577 provides details on the inspection of pipe welding. The inspector should be familiar with the material contained in these documents.

10.3.2 Joints

10.3.2.1 General

Methods of inspection for specific types of joints are discussed in 10.3.2.2 through 10.3.2.5.

10.3.2.2 Flanged and Bolted Joints

Sites should have a program to ensure that flanges are made up properly. Proper makeup of every flange in a piping system is important for reliability. Proper makeup includes the use of the proper gasket and fastener (material, type, and size), proper positioning of the gasket, and proper torquing of the fasteners. The assurance program should include procedures for gasket and fastener selection and fastener torquing. ASME PCC-1 offers good guidance on the proper makeup of bolted flange joints.

The program can incorporate varying degrees of sampling, visual inspection, field testing, and destructive testing of components. Gasket selection can usually be confirmed by visual examination of the gasket's color and markings on the OD surface. Spiral-wound gaskets should be marked and color-coded in accordance with ASME B16.20. Fasteners can be visually examined for proper stampings or markings and PMI tested in accordance with API 578.

Proper gasket positioning and torquing depend on the training and craftsmanship of the pipefitters making up the flanges. Gasket positioning can be checked visually. However, proper torquing is difficult to check, but any observed flange deformation can be a sign of improperly torqued fasteners.

Flanged joints should be visually inspected for cracks and metal loss caused by corrosion and erosion when they are opened. See 10.2.2 for methods of inspection for cracks. Inspection of gasket faces is covered in 10.2.3. Flange joints can be inspected while in service by applying single-element or phased-array UTs to the external surfaces to measure flange face corrosion and to detect ring groove cracking.

Flange bolts should be inspected for stretching and corrosion. Where excessive bolt loading is indicated or where flanges are deformed, a simple inspection can be performed where a nut is rotated along the entire length of the stud. If the stud is stretched, the thread pitch will be changed and the nut will not turn freely. The inspection involves checking to determine whether bolts of the proper specification have been used, and it may involve chemical analysis or physical tests to determine the yield point and the ultimate strength of the material.

If flanges are bolted too tightly, they can bend until the outer edges of the flanges are in contact. When this occurs, the pressure on the gasket can be insufficient to ensure a tight joint. Visual inspection of the gasket will reveal this condition. Permanently deformed flanges should be replaced or refaced.

10.3.2.3 Welded Joints

In some services, welds can preferentially corrode. The inspection program should look at a sampling of welds if corrosion at welds is suspected.

Welded joints may be subject to leaks caused either by cracks or by corrosion or erosion. Cracks in low-alloy steel welds are often associated with excessive hardness resulting from improper control of preheat or PWHT. The hardness of air-hardenable, low-alloy steel welds should therefore be checked after heat treatment. Carbon steel welds in environmental cracking service should be checked for hardness.

Corrosion can occur in the form of pitting that has penetrated the weld or the adjacent heat-affected metal. Both pitting and welding defects can be detected by RT. If severe defects are suspected and RT is not feasible, the affected area can be chipped or gouged out until sound metal is reached, and the groove can be rewelded.

Welded joints in carbon steel and carbon-molybdenum steel exposed to elevated temperatures of 800 °F (426 °C) or greater can be subject to graphitization. When graphitization is suspected, a sample should be taken from a welded joint and examined metallurgically for evidence of excessive graphitization.

10.3.2.4 Threaded Joints

Threaded joints can leak because of improper assembly, loose threads, corrosion, poor fabrication, cross-threading, crack in the root of a thread, or threads that are dirty at the time of assembly. Lack of thread lubricant or the use of the wrong lubricant can also cause leaks. If the leak cannot be stopped by tightening the joint, the joint should be unscrewed and visually examined to determine the cause of the leak.

Caution—A leaking threaded joint should not be tightened while the system is in service under pressure unless there is reasonable certainty that the leak is not caused by a crack in the threads. An undetected crack in a thread root could open up significantly and cause a release of product with serious consequences.

10.3.2.5 Clamped Joints

A clamped joint that depends on machined surfaces for tightness can leak because of dirt, corrosion of the mating faces, mechanical damage, or failure of the clamp to provide a sufficient force on the mating faces for proper contact. A clamped joint that depends on a gasket for tightness can leak because of damaged or dirty gasket seating surfaces or failure of the clamp to provide sufficient pressure on the gasket. If tightening the clamp does not stop the leak, the joint should be dismantled and visually inspected to determine the cause of the leak. ASME PCC-2, Article 306, provides useful guidance on the design, limitations, fabrication, installation, inspection, and testing of mechanical clamps.

When evaluating the use of a clamp, consideration should be given to the possibility of full line separation and the consequence thereof. If credible, the design of a clamp should incorporate axial restraint whether inherent to the clamp design or through external restraints (e.g. strong backs). In addition, the pipe wall thickness should be checked to verify sufficient pipe wall thickness at the ends of the clamp to resist collapsing by the clamping forces. After clamp installation, inspections of the clamp should include verification any strong backs have not been compromised.

10.3.3 Misalignment

Often, misalignment is not apparent until the piping has cooled and has moved to its cold position. The inspector should note, as in 10.1.3, indications of misalignment while the piping is cold. Note especially the hot and cold position of spring hangers to determine if the hangers are adjusting properly to the changes in piping positions from hot to cold. This is especially critical for large-diameter lines, such as catalyst transfer lines in FCC units.

If misalignment of piping was noted during operation, the cause should be determined and corrected. Misalignment is usually caused by the following conditions:

- a) inadequate provision for expansion;
- b) broken or defective anchors or guides;
- c) excessive friction on sliding saddles, indicating a lack of lubrication or a need for rollers;
- d) broken rollers or rollers that cannot turn because of corrosion or lack of lubrication;
- e) broken or improperly adjusted hangers;
- f) hangers that are too short and thus limit movement or cause lifting of the piping;
- g) excessive operating temperature;
- h) failure to remove the spring blocks after system construction.

10.3.4 Vibration

Where excessive vibration or swaying was noted during operation, an inspection should be made for points of abrasion and external wear and for cracks in welds at locations that could not be inspected during operation. The visual inspection methods described in 10.1.5 should be followed. This inspection should be supplemented by surface NDE methods as applicable. The conditions causing excessive vibration or swaying should be corrected.

10.3.5 Hot Spots

The internal refractory should be visually inspected for bypassing or complete failure in locations of hot spots noted during operation on refractory-lined piping (see 10.1.7). The cause of the hot spot should be corrected. The pipe wall near the hot spot should be visually inspected for oxidation and resultant scaling. All of the scale should be removed, and the remaining sound metal should be examined for incipient cracks. The sound metal should be measured to ensure that sufficient thickness remains for the service. The OD of piping in high-temperature service—metal temperatures of about 800 °F (427 °C) and above—should be measured to check for creep or deformation with time under stress. To ensure that an in-service fracture will not occur, the amount of creep permitted should be based on established data for the desired service life.

10.3.6 Expansion Joints

Inspection of expansion joints involves examinations both at maintenance outages and during operation. While in operation, the “hot” settings and position of connected pipe supports/guides and the expansion joint should be recorded prior to shutdown and shortly after start-up. Comparing these measurements allows for changes to be identified and subsequently evaluated. In addition, the joint and attached piping should be visually examined for alignment, distortion, cracks, and leaks. A check should be made prior to start-up to make sure all stops, and other restricting devices are removed, and all components are positioned in the cold setting. Temporary supports may be left in place if they will not interfere with the piping expansion in the hot setting.

Infrared thermography examination of the joint in high-temperature services can identify hot spots and bulk temperature to determine if both the joint is operating within its design temperature and if any internal fiber blanket and liner associated with the joint is functioning as designed.

During maintenance outages, additional inspection activities may be performed. As stated previously, the “cold” position and settings should be recorded and compared to previous “cold” and “hot” measurements. Changes should be reviewed against the design. The expansion joint should be visually examined externally and, if possible, internally. Any external coverings should be removed to facilitate the inspection. The fabric in fabric joints should be examined for rips, holes, and flexibility. Metal attachment rings and bolting should be examined for distortion and corrosion. Metallic bellows may be examined with dye penetrant examination, ET, and UT for cracking. Cracks can occur in convolutions, at piping attachment fillet welds, and on any internal liner attachment welds. Thinning and pitting can occur in some services, and evidence for these should be investigated during internal inspections.

10.3.7 Flexible Hoses

Flexible hoses utilized in hydrocarbon or other hazardous service should be individually identified and include appropriate service (chemical) limitations and acceptable operating conditions. Generally, there are two purposes for flexible hoses: one being installed in lieu of hard piping and the other being used for short-term purposes. The purpose of the flexible hose should be taken into consideration when determining if the flexible hose should be inspected and how it should be inspected.

Flexible hoses used in permanent installations should be periodically inspected with the hard piping it is attached to or more frequently if determined necessary by the owner-operator. Flexible hoses used in

temporary applications should be cleared of process material, cleaned, and stored appropriately (per manufacturer's instructions where available) when not in use to minimize both mechanical damage and exposure to environmental conditions and chemicals that could compromise one or more components of the hose assembly.

Each flexible hose (new and used) should be inspected prior to being placed in service. This inspection should include a verification of its intended service (process chemicals and temperature/pressure rating) and overall condition (looking for mechanical damage to connections, fittings, flanges, etc.) and that the periodic inspection has been performed.

A complete inspection of the hose should be performed periodically. This inspection should include the following.

- a) Ensure the hose has been individually identified (ID tag) and that the records contain appropriate design conditions and service limitations or compatibility.
- b) Verify diameter, length, and end fittings for individual assemblies and compare with existing ID tags and documentation.
- c) Verify the hose and fitting pressure ratings are within the design parameters for hydrostatic proof pressure test (generally 1.5 times MAWP) and check the condition of the fittings (thread condition and gasket or sealing surface condition to provide a proper seal). Fittings should also be examined for mechanical damage from overtightening of the threads or overtorquing of the bolted assembly, causing flange face rotation. The hose to fitting attachment point should also be inspected for loose or damaged clamps or compression fittings.
- d) Perform a visual inspection of the hose cover for any cuts, gouges, breaches, fraying, or other defects where reinforcement is exposed. The hose assembly should also be inspected for excessive abrasion damage to the outer covering/jacket and damage from heat (brittleness and/or cracking).
- e) Inspect for damage from excessive bending (kinking), which may produce partial crushing/flattening of the hose, crimping, or excessive strain at end connections. Check minimum installed bend radiuses to the manufacturer's recommendations.
- f) To the extent possible, examine the internal condition of the hose, looking for signs of erosion, cracking, or chemical attack/damage of a nonmetallic liner (swelling, tears, abrasion/roughness, etc.).
- g) Additional inspections may include the following:
 - 1) visual inspection of the hose tube with a boroscope or videoprobe for general condition on the interior liner (looking for blisters, cracks, or other defects);
 - 2) for fluoropolymer and thermoplastic hose equipped with an internal bonding, perform a test to ensure the electrical continuity between the end fittings;
 - 3) if the transfer fluid inside the hose is nonconductive, then perform an electrical conductivity test to ensure the grounding/bonding of the hose;
 - 4) check for appropriate alloy composition (PMI) per manufacturers and equipment records; note that this may only be an initial inspection unless hose fittings or other components may be changed or modified;
 - 5) on-stream inspection using infrared thermography examination may help identify damage to one or more of the hose components/layers;

- 6) fittings may be examined with dye penetrant, ET, and/or UT methods to identify cracking or other damage;
- 7) perform a hydrostatic pressure test in accordance with the manufacturer's recommended design specifications (limited by the lowest pressure rating of included component);
- 8) perform the original equipment manufacturer's recommended inspection and testing activities.

As effective inspections of process hoses are difficult, some owner-operators stamp and track process hoses, periodically pressure test them, and require replacement after a set amount of service time based on risk and type of hose. Additionally, visual inspection checklists can be used for issues that should be periodically checked to verify the integrity of the hose.

10.4 Thickness Measurements

10.4.1 Ultrasonic Examination

10.4.1.1 General

Three factors considered when designing equipment intended to contain the pressure and load-bearing forces are shape, the material of construction, and thickness.

Of the three main factors, the thickness can change with time due to corrosion. The industry relies predominantly on the remaining thickness of the component after the equipment is designed, fabricated, and installed to determine if it is fit for continued service. Once the equipment is in routine operation, thickness assessments become the most common practice for inspecting for thinning. However, the identification of credible damage mechanisms may also be included (e.g. cracking, embrittlement, distortion, etc.). Measuring the thickness of the equipment in various designated locations (i.e. CMLs) is the most common condition assessment practice performed on piping.

Corrosion specialists in the industry have identified damage mechanisms, described in API 571, that result in loss of metal thickness. After the credible damage mechanisms have been identified, susceptible locations (e.g. CMLs) are determined and the wall thickness is measured and recorded. This occurs on a routine basis based on the risk and/or assigned/established corrosion rates.

Numerous factors are considered when selecting the best tools to measure thickness, including the following:

- component shape;
- material of construction;
- temperature during measurement;
- damage predicted;
- coatings on the ID and/or OD;
- access;
- available resources for conducting the measurements.

Thickness measurement can be performed using audio, mechanical, sonic, radiation, and electromagnetic devices.

Sonic devices use sound waves and electronics to measure wall thickness. The frequency of the sound waves used is considered “ultrasonic” meaning greater than 20K cycles per second; thus, the terminology “ultrasonic examination technique.”

Radiation is used as a means of energy to penetrate metal. The amount of radiation penetrating metal is measured by exposing film or imaging plates. The use of radiation to create an interpretable image is referred to as “radiographic examination technique.” The most common RT technique is called “profile radiography.” Wall thickness measurement and detection of wall loss patterns are most frequently performed using profile RT. Additionally, “density radiography” is also used to look for areas of localized corrosion and pitting of the ID surface of a component.

The thickness of a material can be expressed in many ways. Some examples include the following.

- Nominal Thickness—The thickness of the supplied material of construction, originally designated by the design criteria, but usually oversized due to the manufacturing process and its tolerances (or as made available by shop supplies).
- Minimum Remaining Wall Thickness—Wall thickness measurement at the thinnest location.
- Minimum Required Wall Thickness—The thickness without corrosion allowance for each component of a piping system based on the appropriate design code calculations and code allowable stress that consider pressure, temperature, mechanical, and structural loadings.
- Average Wall Thickness—A number of thickness measurements collected at a single small area (e.g. a 2” diameter examination point) and used to calculate an average thickness at the CML.

10.4.1.2 Thickness Instruments

10.4.1.2.1 General

UT instruments are the primary means of obtaining thickness measurements on equipment. RT and real-time RT may also be used in a limited way to determine the thickness of piping components. Methods such as depth drilling (e.g. sentinel or tell-tale holes), the use of corrosion buttons, and the use of test holes may be applied at some special locations. However, these methods have generally been replaced by NDE methods of thickness gauging, such as ultrasonic thickness measurements.

Manufacturers of UT equipment have designed instruments specifically for thickness measurements and are referred to as ultrasonic thickness instruments and in some cases, the word “instrument” is substituted using the word “gauge.” There are three types of digital ultrasonic thickness instruments: numeric thickness readout, A-scan with numeric thickness readout, and flaw detectors. The major advantages of UT instruments are as follows.

- a) Personnel safety is enhanced due to the compact size and minimal weight. This is advantageous when climbing, during rope access and in cases where physical exertion is necessary to obtain access.
- b) Features that increase the accuracy of measurements when utilized on pipe with coatings, pipe operating at elevated temperatures, and pipe with uneven reflective surfaces due to corrosion.
- c) The ability to connect to software programs used for managing mechanical integrity programs.

UT instruments are simple to operate and economical to purchase compared to more sophisticated ultrasonic instruments for flaw detection, sizing, and characterization. However, the degree of training and experience required to ensure that true and accurate measurements are obtained can be considerable and should not be underestimated. Owner-operators should ensure that adequate training, examination, and certification of personnel takes place, such as outlined in ASNT SNT-TC-1A or equivalent international

standards. Personnel using these devices should have training on the proper use of this equipment, including ultrasonic theory, high-temperature thickness measurements, corrosion evaluation, mid-wall anomalies, the potential for “doubling,” and equipment operations.

10.4.1.2.2 Numeric Thickness Readout

Thickness readout instruments are small handheld pulse-echo thickness gauges with only a numeric readout. These instruments are typically equipped with dual-element pitch-catch transducers. The instruments have a probe zero and a velocity setting for calibration on various materials. The range for these instruments is usually from 0.040 in. to 20.000 in., depending on the configuration. The instruments operate by measuring the time between the initial pulse (IP) and the first echo.

The use of numeric thickness readout-only instruments should be carefully considered as they have been misused and misapplied within the industry and can lead to erroneous and inaccurate results.

10.4.1.2.3 A-scan with Numeric Thickness Readout

A-scan instruments with a numeric thickness readout are divided into two groups: thickness measurement (only) and flaw detectors.

A-scan thickness measurement instruments incorporate a numeric display and an electronic display for viewing an A-scan presentation. The displays are usually liquid crystal displays or light-emitting diodes. Some of these instruments can display both A- and B-scans.

The advantage of an A-scan display over a numeric display is that it allows the examiner to view the ultrasonic waveform to verify the proper signal is being measured by the instrument. This is extremely important in the case of doubling and for evaluating a laminar indication versus corrosion damage.

The A-scan display aids the examiner in distinguishing between a corroded surface and a mid-wall anomaly (e.g. laminar inclusion). The reflected signal from a laminar inclusion will come straight up from the baseline at a point prior to the reflected back wall signal indicating the depth. Often, while scanning a corroded area, the signal from corrosion will break the baseline at the back wall signal and the corrosion signal will move toward the IP signal until the minimum thickness is reached. This movement is due to the sound reflecting from the edges of the corrosion until the thinnest area is being reflected. This movement of the corroded signal is often referred to as “walking the signal.”

A-scan instruments typically can operate in either of two-timing modes, the IP timing mode or the multiple echo mode. The IP timing mode measures the transit time from the IP to the first echo. The multiple echo mode allows the examiner to set the instrument to measure between a set of multiple successive echoes instead of the IP first in order to establish the thickness.

The multiple echo mode is used for measuring the remaining thickness on specimens with coated surfaces without including the coating thickness. This is accomplished by measuring the travel time between two successive back wall signals to obtain the thickness of the material and not including the travel time due to the thickness of the coating. When using this mode, the examiner should pay careful attention to the A-scan display to ensure that the proper signals are being measured.

Corrosion evaluation should be conducted using the IP timing mode. The reflected energy on rough and corroded or pitted surfaces is often only strong enough to produce a single signal. The instrument will indicate “0.000” when in multiple echo mode because it requires two echoes to measure.

In cases where a component is painted at the measurement location and is corroded on the reflection side (which can cause a lack of sufficient echo-to-echo signal and therefore measurement error), the paint should be removed for accurate thickness measurements.

UT thickness gauges and certain transducers can measure the thickness of paint and wall thickness simultaneously.

These instruments primarily use a 0.250 in. to 0.500 in. diameter, 2.0 MHz to 5.0 MHz, dual-element pitch-catch search unit; however, some instruments have options to use single-element delay or even EMATs.

10.4.1.2.4 Ultrasonic Flaw Detectors with a Numeric Display

Ultrasonic flaw detectors with a numeric display are similar to the A-scan thickness gauges in that they have both an A-scan and a numeric display and can be used with single- or dual-element transducers. These instruments are more advanced than the others and typically have more options and features, including the capability for angle beam examinations. However, modern UT thickness gauges utilize features that enhance the accuracy of thickness measurement, typically resulting in improved accuracy of measurement over flaw detectors.

Flaw detectors with numeric displays can be operated in either the IP or multiple echo timing modes.

Other applications requiring the use of ultrasonic flaw detectors are weld quality examinations, advanced flaw sizing, and high-temperature hydrogen attack detection. Weld quality examinations (angle beam) use specially designed transducer wedges to generate shear waves at 45°, 60°, or 70° for detecting, evaluating, and sizing flaws. Flaws that can be detected are cracks, slag, lack of fusion, incomplete penetration, and porosity.

Advanced crack-sizing techniques for measuring the through-wall extent of the cracks include the use of tip diffraction, high-angled L-waves, 30-70-70 search units, and bimodal search units. All of the advanced techniques require additional hours of classroom and field experience. The examiner is also required to pass a performance-based demonstration examination. Other advanced UT technologies available for detecting and evaluating and sizing flaws include time-of-flight diffraction and phased array.

High-temperature hydrogen attack can be detected and evaluated utilizing other highly specialized ultrasonic techniques as outlined in API 586.

10.4.1.2.5 Some Factors Affecting Measurement Accuracy

Ultrasonic velocities are different in different materials. It is important to use the proper velocity to obtain accurate thickness measurements. An ultrasonic instrument determines the thickness by the following equation:

$$\text{Thickness} = \frac{(\text{time of round trip sound travel}) \times (\text{velocity for material})}{2}$$

The round-trip sound travel is measured from pulse generation to the time the sound waves from the back wall or another reflector is received. The wrong velocity can either increase or decrease the as-measured ultrasonic thickness.

Laminar inclusions can also cause erroneous readings. Because laminar inclusions create a planar interface perpendicular to the direction of wave travel, they can reflect the sound back to the transducer. This reflected signal can be misinterpreted as being the back wall signal and will calculate a thinner reading.

If the ID surface is extremely rough or an irregular-shaped pit is encountered, often the only indication the examiner may encounter is a lower amplitude back wall signal or a complete loss of the back wall signal. This reduction or loss is due to the dispersion of the sound. In turn, there is not enough ultrasonic energy received by the instrument to produce a signal above the noise level. In cases such as these, the examiner should increase the gain setting on the instrument until the area where the diminished signal or loss of signal occurred can be fully evaluated to the extent the examiner can determine a minimum thickness.

Doubling occurs when measuring thin materials usually less than 0.100 in. (2.5 mm). Doubling results in reading much thicker than the actual wall thickness. The reflected back wall signal is masked by the noise from the IP, and the instrument reads the second or third reflection. Another occurrence of doubling can be caused in extremely thin materials below the instrument's (i.e. transducer) ability to separate the signals adequately for proper measurement of the gate function. This results in the sound reflecting in the material producing an extra skip distance before it is received, thereby doubling the travel time or sound distance and in turn doubling the measured thickness. It is equally important when using echo-to-echo mode due to mode-converted shear wave echoes occurring between the back wall echoes. The measuring gate can lock onto the signal mode converted shear wave echo, causing incorrect wall thickness measurement, as shown in Figure 29.

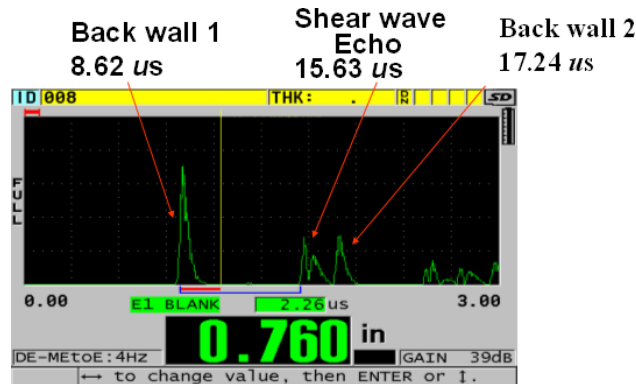

Figure 29—Case of Doubling due to Mode Converted Shear Wave Echo Occurring between the Backwall Echoes

Each search unit should be tested to determine the minimum measurable thickness. Sample steps are as follows:

- measure the thickness of a set of feeler gauges beginning at 0.100 in. (2.5 mm);
- measure the 0.090 in. (2.3 mm), 0.080 in. (2.0 mm), and so on, subtracting 0.010 in. (0.25 mm) every reading until the as-measured thickness is two times or more than the actual thickness;
- take the thickness where the doubling occurred and multiply by 1.5 times, and this should be the minimum measurable thickness for that search unit.

10.4.1.3 Corrosion Evaluations

The best search units for conducting a corrosion evaluation are dual-element transducers. The piezoelectric elements in these search units are placed on slight angles for direct reflection of the transmitted sound toward the receiving transducer. This tilting of the transducers provides some pseudo-focusing of the sound beam. The dual-element search units provide better near-surface detection than conventional single-element search units.

The frequency for the majority of search units ranges from 2 MHz to 5 MHz and the diameter from 0.25 in. to 0.500 in. (6.3 mm to 12.7 mm). Special applications such as thick materials [> 6.00 in. (152 mm)], product forms such as castings, or coarse grain materials such as high-alloy or high-nickel steels can require lower frequencies (1 MHz) and/or larger diameter search units.

Search units used for corrosion detection or evaluation should have a good wear surface on the face of the search unit to allow the examiner to scan corroded areas for the minimum reading and minimize the wear on the search unit. When conducting corrosion detection or evaluation, the examiner should scan the area

of interest with the search unit in lieu of conducting individual point measurements. Scanning provides a greater chance of detecting small diameter (less than one-half of the search unit diameter) indications. The examiner should not scan faster than the A-scan displays refresh rate to avoid missing a small indication. This is typically 6 in./s (152 mm/s) or less. Additionally, the examiner should overlap each scan path by a minimum of 10 % of the transducer diameter.

10.4.1.4 High-temperature Thickness Measurements

The search unit is the most important component of the thickness measurement equipment for high-temperature measurements. Some high-temperature search units are designed to withstand temperatures up to 1000 °F (538 °C) for very brief durations of time.

Special delay-line materials and water-cooled transducers are available that permit the use of pulse-echo instruments at temperatures up to 1100 °F (593 °C). Most high-temperature dual-element search units are manufactured with the delay material built into the case, whereas most single-element search units come with replaceable delays.

The duty cycle is another critical factor for high-temperature search units. The search unit should be allowed to cool down between thickness measurements. This is especially critical in the case of dual-element search units. Even though these search units are manufactured to withstand high temperatures, continued use at elevated temperatures will cause these units to begin to breakdown. As a rule of thumb, the search unit should be allowed to cool down between thickness measurements where the examiner can comfortably hold it in their bare hand.

The second most critical element for performing high-temperature thickness measurements is the ultrasonic couplant. There are several high-temperature couplants commercially available. The desirable characteristics of a couplant should be one with good acoustic properties, good chemical stability at elevated temperatures, the ability to withstand decomposition, the ability to remain on vertical surfaces for 10 seconds or longer, high boiling temperature, nonflammable, and nontoxic.

The test specimen temperature also affects the UT thickness measurement. As the test specimen temperature increases above ambient temperature, the velocity of the material decreases, thereby increasing the as-measured ultrasonic thickness by a factor of 1 % / 100 °F (1 % / 55 °C).

Some modern UT thickness gauges have a feature that provides automatic temperature compensation. The surface temperature to be examined is measured with a pyrometer. The operator keys in the temperature of the surface being examined. The UT thickness gauge automatically compensates for the change in velocity due to elevated temperature (see Figure 30 for an example). The inspector should be cautioned when using such gauges. The UT thickness procedures should clearly describe how thickness data are collected when the metal temperature is greater than a defined temperature. The inspector should understand if and when the Inspection Data Management System (IDMS) that will be storing and analyzing the thickness data may also be used to compensate for temperature differences.

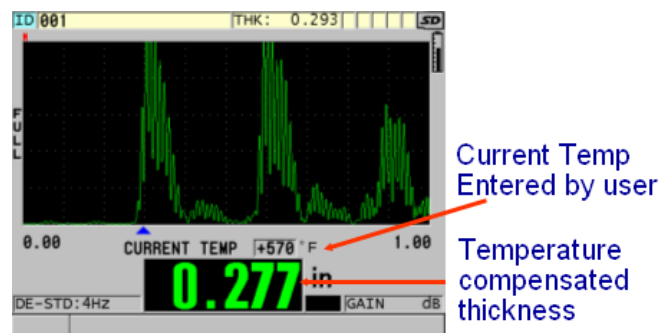

Figure 30—Example of Screen Display of UT Thickness Gauge with Automatic Temperature Compensation

The examiner must wear the proper PPE when conducting high-temperature thickness measurements for protection from the radiated heat.

10.4.2 RT

Gamma-radiographic techniques provide accurate pipe wall measurements and permit inspection of the internals of some equipment. The primary functions of this method are to detect metal loss and check weld quality. RT has the following advantages:

- a) pipe insulation can remain intact;
- b) the metal temperature of the line has little bearing on the quality of the radiograph, provided the film cassette can be protected from the heat of the piping;
- c) radiographs of small pipe connections, such as nipples and couplings, can be examined for thread contact, corrosion, and weld quality;
- d) the film provides a permanent visual record of the condition of the piping at the time of the radiograph;
- e) the position of internal parts of valves (dropped gates) can be observed;
- f) radiographic equipment is easily maneuverable in the refinery or chemical plant;
- g) isotope RT is not an ignition source in the presence of hydrocarbons;
- h) pitting and other nonuniform corrosion can be identified;
- i) provides a view of a large area.

Gamma rays traveling through the pipe wall between the outside and inside radii of the pipe must penetrate metal that is approximately four times the wall thickness of the pipe. Most of the rays are absorbed by the metal, leaving an unexposed area on the film. This area that is lighter on the darkened film represents a slightly enlarged projected image of the pipe wall. The image can be measured, and a correcting calculation can establish the thickness of the pipe wall. Any deposits or scale inside the pipe usually appear on the developed film as distinctly separate from the pipe wall. Pitting can also be visible on the film.

Computed radiography can be utilized in place of film RT, reducing exposure times and producing a digital image that is easily archived and electronically transmitted.

Because isotope RT gives the inspector an “internal look” at the pipe, the somewhat higher cost of this inspection can be more than offset by the data obtained.

Ionizing radiation is the base principle in industrial RT, and the most common radiation sources are iridium and cobalt. There are significant safety issues surrounding the use of ionizing radiation such that personnel performing RT are required to be trained and certified as identified in API 570 and ASME *BPVC*, Section V, plus any jurisdictional requirements. Correct procedures must be established and implemented to ensure the safety of examiners and all other plant personnel.

RT thickness measurement accuracy relies somewhat on the abilities of the radiographic technician exposing the films and the person reviewing them. When using RT for this purpose, it is advisable to develop a written practice defining the method(s) of film placement, exposure, and reading or interpreting them. Radiographic test shots should be taken of piping, which can be examined with UT thickness measurements to determine the limits of accuracy of the RT once it has been developed. In addition, a test piece of known thickness can be placed on the same plane as the radiograph, which will help define radiographic magnification factors. Multiple caliper thickness readings of the shot will improve the precision.

When radiographic inspection is being performed, process-unit control systems, which use isotopes in liquid-level indicators and controls, occasionally give erroneous indications on control panels. Flame detectors used to indicate a furnace or boiler fire can also be affected. Unit operators must be warned of this possibility.

Profile RT is particularly useful for identifying internal and external corrosion of small connections, such as bleed lines and gauge connections, which are especially susceptible to external corrosion from CUI because it is difficult to obtain a good seal in the insulation.

Radiographs of piping are shown in Figure 31, Figure 32, and Figure 33.

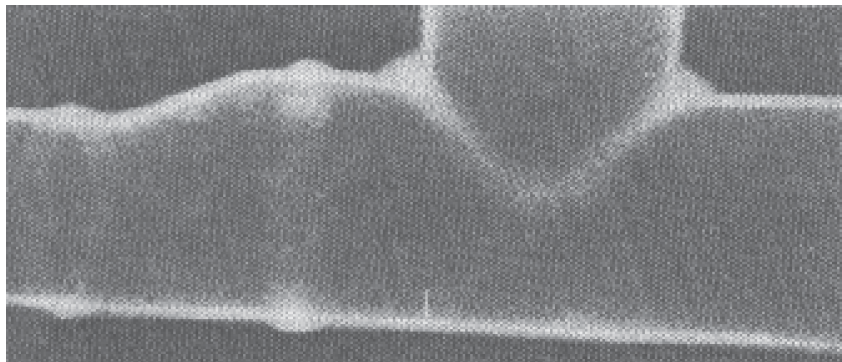

Figure 31—Radiograph of a Catalytic Reformer Line

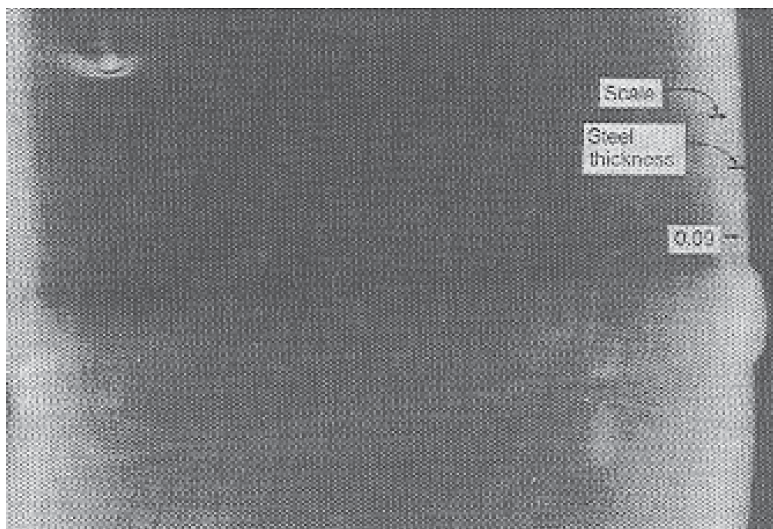

Figure 32—Radiograph of Corroded Pipe Whose Internal Surface Is Coated with Iron Sulfide Scale

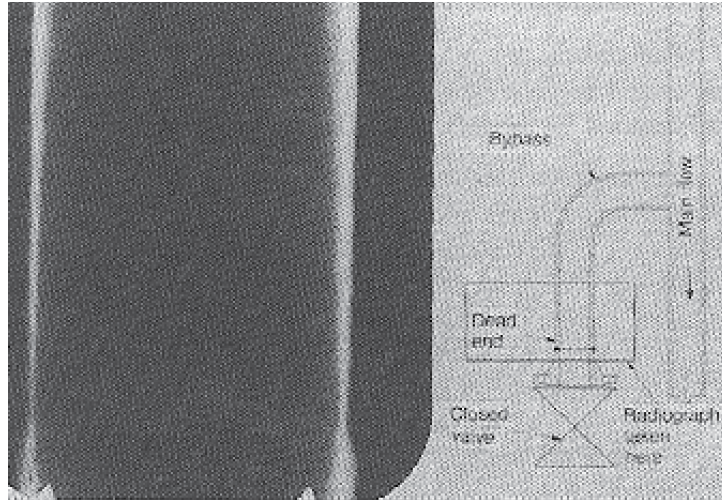

Figure 33—Sketch and Radiograph of Dead-end (Deadleg) Corrosion

10.4.3 Caliper Thickness Measurements

When piping is opened, the thickness of the pipe and fittings can be measured behind the flange using transfer or indicating calipers. The thickness of inaccessible piping that cannot be measured by radiographic or ultrasonic instruments during operation can be measured with these instruments during a shutdown. If need be, the thickness of valve bodies and bonnets and pipe fittings can be measured using transfer or indicating calipers that have special legs designed to reach normally inaccessible areas.

10.5 Determination of Minimum Required Thickness

10.5.1 Piping

10.5.1.1 General

ASME B31.3 contains formulas and data for determining the minimum required wall thickness for new uncorroded piping. The specification relates thickness, diameter, joint efficiency, and allowable stress to maximum safe working pressure. In specifying piping for original installation, ASME B31.3 requires that the following be considered when pipe thickness is determined:

- a) corrosion allowance;
- b) threads and other mechanical allowances (consideration should be given to crevice corrosion and loss of thickness due to cutting the threads);
- c) stresses caused by mechanical loading, hydraulic surge pressure, thermal expansion, and other conditions;
- d) reinforcement of openings.

Additional thickness is nearly always required when item a) through item d) are considered. Normally, the engineer will select the pipe schedule that accommodates the required thickness plus the manufacturing tolerance permitted by the pipe material specification.

Additional thickness is often needed near branch connections. This additional thickness is usually provided by one of the following:

- a) a welding tee;

- b) a saddle;
- c) an integrally reinforced branch outlet (e.g. a weldolet); or
- d) the header and/or run pipe thickness is greater than required by design conditions.

Caution—Caution should be exercised in calculating the retirement thickness for piping with branch connections reinforced per item d). These calculations should be performed by a piping engineer.

For in-service piping subject to localized damage (e.g. pitting, cracking, blistering, gouging), as well as weld misalignment and distortion, the inspector may choose to evaluate the piping strength and suitability for continued service utilizing the approach discussed in API 579-1/ASME FFS-1. Such an analysis should be performed by, or under the direction of, a piping engineer.

10.5.1.2 Pressure Design Thickness

ASME B31.3 contains a formula for determining the required thickness of new, uncorroded, straight pipe subject to internal pressure. API 570 permits the use of the simple Barlow formula to determine the required wall thickness for in-service piping. ASME B31.3 provides the guidance of when other equations are applicable. The Barlow formula is as follows:

$$t = \frac{PD}{2SE}$$

where

- t is the pressure design thickness for internal pressure, in inches (millimeters);
- P is the internal design gauge pressure of the pipe, in pounds per square inch (kilopascals);
- D is the OD of the pipe, in inches (millimeters);
- S is the allowable unit stress at the design temperature, in pounds per square inch (kilopascals);
- E is the longitudinal quality factor.

The Barlow formula gives results that are practically equivalent to those obtained by the more elaborate ASME B31.3 formula except in cases involving high pressures where thick-walled tubing is required. Metallic pipe for which $t \geq D/6$ or $P/SE > 0.385$ requires special consideration.

ASME B31.3 also contains the allowable stresses to be used in the formulas contained in that publication. These allowable stresses include a factor of safety and are functions of the pipe material and the temperature.

10.5.1.3 Structural Minimum Thickness

In low-pressure and low-temperature applications, the required pipe thicknesses determined by the Barlow formula can be so small that the pipe would have insufficient structural strength. For this reason, an absolute minimum thickness to prevent sag, buckling, and collapse at supports should be determined by the user for each size of pipe, dependent upon the materials of construction. The pipe wall should not be permitted to deteriorate below this minimum thickness regardless of the results obtained by the ASME B31.3 or Barlow formulas.

The owner-operator shall specify how structural minimum thicknesses are determined. An example table of calculated structural minimum thickness for straight spans of carbon steel pipe is provided in Table 5. Additional consideration and allowances may be required for the following conditions:

- a) screwed piping and fittings;
- b) piping diameters greater than 24 in. (610 mm);

- c) temperatures exceeding 400 °F (205 °C) for carbon and low-alloy steel;
- d) higher alloys (other than carbon steel and Cr-Mo);
- e) spans in excess of 20 ft (6 m);
- f) high external loads (e.g. refractory lined, pipe that is also used to support other pipe, rigging loads, and personnel support loading);
- g) excessive vibration.

Engineering calculations, typically using a computerized piping stress analysis program, may be required in these instances to determine structural minimum thickness.

Austenitic stainless steel piping often has lower minimum structural thickness requirements based on their typically higher strength, higher toughness, and thinner initial thicknesses of piping components. Separate tables are often created for stainless steel piping.

Table 5—Minimum Structural Thickness and Minimum Alert Thicknesses for Carbon and Low-alloy Steel Pipe

NPS	Default Minimum Structural Thickness for Temperatures < 400 °F (205 °C) in. (mm)	Minimum Alert Thickness for Temperatures < 400 °F (205 °C) in. (mm)
1/2 to 1	0.07 (1.8)	0.08 (2.0)
1 1/2	0.07 (1.8)	0.09 (2.3)
2	0.07 (1.8)	0.10 (2.5)
3	0.08 (2.0)	0.11 (2.8)
4	0.09 (2.3)	0.12 (3.1)
6 to 18	0.11 (2.8)	0.13 (3.3)
20 to 24	0.12 (3.1)	0.14 (3.6)

10.5.1.4 Minimum Required Thickness

Generally, piping is replaced and/or repaired when it reaches the minimum required thickness unless a Fitness-For-Service analysis has been performed that defined additional remaining life. The minimum required thickness is the greater value of the pressure design thickness or the structural minimum thickness. The following steps should be followed when determining the minimum required thickness at a CML.

- a) Step 1: Calculate the pressure design thickness per rating code.
- b) Step 2: Determine the structural minimum thickness per the owner-operator table or engineering calculations.
- c) Step 3: Select the minimum required thickness. This is the larger of the pressure design thickness or structural minimum thickness determined in Step 1 and Step 2.

For services with high potential consequences if a failure were to occur, the piping engineer should consider increasing the minimum allowed thickness above the one determined above in Step 3. This would provide extra thickness for unanticipated or unknown loadings, undiscovered metal loss, or resistance to normal abuse.

EXAMPLE 1: Determine the minimum required thickness for an NPS 2, ASTM A106, Grade B pipe designed for 100 psig @ 100 °F. $P = 100$ psig, $D = 2.375$ in., $S = 20,000$ psi, $E = 1.0$ (since seamless), $Y = 0.4$.

- Step 1: Calculate pressure design thickness per rating code. (In this example, the ASME B31.3 design formula was used.)

$$t = \frac{P \times D}{2 \times S \times E + (P \times 0.4)} = \frac{100 \times 2.375}{2 \times 20,000 \times 1 + (100 \times 0.4)} = 0.006 \text{ in.}$$

NOTE If this NPS 2 pipe was 100 % supported (e.g. laying on flat ground), then 0.006 in. would hold the 100 psig of pressure. This thickness includes a 3-to-1 safety factor; however, it would not hold up in the pipe rack.

- Step 2: Determine structural minimum thickness per owner-operator table or engineering calculations. From Table 5, the default structural minimum thickness is 0.070 in.
- Step 3: Select the minimum required thickness. This is the larger of the pressure design thickness or structural minimum thickness determined in Step 1 and Step 2. The larger value of 0.006 in. and 0.070 in. is 0.070 in.

EXAMPLE 2: Determine the minimum required thickness for a 14 NPS, ASTM A106, Grade B pipe designed for 600 psig @ 100 °F, $D = 14$ in., $S = 20,000$ psi, $E = 1.0$ (seamless), $Y = 0.4$.

- Step 1: Calculate pressure design thickness per rating code. (In this example, the ASME B31.3 design formula was used.)

$$t = \frac{P \times D}{2 \times S \times E + (P \times 0.4)} = \frac{600 \times 14.0}{2 \times 20,000 \times 1 + (600 \times 0.4)} = 0.208 \text{ in.}$$

- Step 2: Determine structural minimum thickness per owner-operator table or engineering calculations. From Table 5, the structural minimum thickness is 0.110 in.
- Step 3: Select the minimum required thickness. This is the larger of the pressure design thickness or structural minimum thickness determined in Step 1 and Step 2. The larger value of 0.208 in. and 0.110 in. is 0.208 in.

10.5.1.5 Minimum Alert Thickness

Users may establish a minimum alert thickness with values greater than either the minimum structural thickness or the pressure design thickness (whichever governs the minimum required thickness). Alert thicknesses are often input into the facility's IDMS. The alert thickness signals the inspector that it is time for a remaining life assessment. This could include a detailed engineering evaluation of the structural minimum thickness, a Fitness-For-Service assessment, or the development of future repair plans. In addition, when a CML reaches the alert thickness, it raises a flag to consider the extent and severity at other possible locations for the damage mechanism. Alert minimum thicknesses are usually not intended to mean that pipe components must be retired when one CML reaches the default limit. Table 5 shows an example of alert thicknesses for carbon and low-alloy steel pipe that could be used in conjunction with the default minimum structural thicknesses.

10.5.2 Valves and Flanged Fittings t_{\min}

Valves and flanged fittings are subject to stress both from internal pressure and from mechanical loadings and temperature changes. Valves are also subject to closing stresses and stress concentrations because of their shape. These stresses are difficult to calculate with certainty. For this reason, the thickness of valves and flanged fittings is substantially greater than that of a simple cylinder.

ASME B16.34 establishes the minimum valve wall thickness at 1.5 times (1.35 times for Class 4500) the thickness of a simple cylinder designed for a stress of 7000 psi (48.26 MPa) and subjected to an internal pressure equal to the pressure rating class for valve Classes 150 to 2500. The actual valve wall thickness requirements provided in Table 3 of ASME B16.34 are approximately 0.1 in. (2.54 mm) thicker than the calculated values. Valves furnished in accordance with API 600 have thickness requirements for corrosion and erosion in addition to those provided in ASME B16.34.

The formula for calculating the minimum required thickness of pipe can be adapted for valves and flanged fittings by using the factor of 1.5 and the allowable stress for the material specified in ASME B31.3.

$$t = 1.5 \times \left[\frac{P \times D}{2 \times S \times E} \right]$$

where

- t is the pressure design thickness for internal pressure, in inches (millimeters);
- P is the internal design gauge pressure of the pipe, in pounds per square inch (kilopascals);
- D is the OD of the pipe, in inches (millimeters);
- S is the allowable unit stress at the design temperature, in pounds per square inch (kilopascals);
- E is the longitudinal quality factor.

This calculated thickness will likely be too thin and impractical for structural loads (as is the case with many piping systems); therefore, minimum thicknesses should be established based on structural needs.

The equations described above do not apply to welded fittings. The equations for pipe can be applied to welded fittings using appropriate corrections for shape, if necessary. A piping engineer should be consulted to see if such calculations are necessary.

10.6 Other Inspection Methods/Techniques

10.6.1 Special Methods of Detecting Mechanical Damage (Future Content)

10.6.2 Metallurgical Changes and In Situ Analysis of Metals (Future Content)

10.6.3 Positive Material Identification (Future Content)

10.6.4 Metal Sample Extraction (Future Content)

10.6.5 Hammer Testing

Hammer testing of piping, valves, and fittings for thickness is an outdated test method in which the component is struck with a hammer in order to listen to the sound or attenuation. The type of sound can be used by an experienced inspector in hammer testing to differentiate thin metal from thicker metal. While some experienced inspectors may gain some knowledge about a pipe's thinness using this technique, the difficulties of calibrating and standardizing a hammer test put this technique outside the scope of modern recommended practices.

Hammer testing of on-stream piping has caused leaks where the hammer impact broke off corrosion scale and where the hammer penetrated thin wall presenting a safety and process safety hazard. For these reasons in addition to the fact it is a qualitative technique, most sites do not allow hammer testing. However, individual sites may choose to allow hammer testing of certain lines but should do so only after evaluating the hazards involved and assessing whether the hammer strikes will damage the piping or cause a leak.

Hammer testing is still considered a valid test for the following:

- a) support anchor or flange bolt tightness by tapping on the nut and monitoring for movement;
- b) identifying loose or broken parts;
- c) checking the piping to ensure that it has drained properly of liquid or if it contains excess process or corrosion scale; tapping the pipe and hearing a dull thud rather than a ring (attenuation) is an indication of a problem.

10.6.6 Tell-tale Hole Drilling

The use of tell-tale holes is a historical practice to determine when the corrosion allowance had been consumed by resulting in a leak that could then be observed. This practice has been abandoned by most users in favor of more conventional, industry-accepted, nondestructive inspection methods (e.g. digital UT, profile RT, etc.) However, some locations still have older piping systems that were designed with tell-tale holes and as such, it is important to identify these older systems and develop appropriate inspection, repair, and replacement plans.

Tell-tale drilling (also referred to as sentinel holes or delforez holes) is the application of small pilot holes [e.g. $\frac{1}{8}$ in. (3.2 mm) diameter] drilled into the pipe component wall using specified and controlled patterns and depths. The intended purpose of the tell-tale holes was to allow a small “controlled” leak that could be visually discovered while there is still sufficient pipe wall remaining to prevent a major rupture. There are several potential problems associated with mechanical integrity/inspection programs based on tell-tale holes and they should not be considered as a substitute for modern conventional inspection methods designed to target credible damage mechanisms in well-defined circuits. There have been a number of events in industry that tell-tale holes have failed to prevent (e.g. cases where there was localized corrosion, cases where a small tell-tale leak under insulation resulted in significant external corrosion of the pipe that went undetected, cases where the pipe failed because the tell-tale hole was plugged off with paint or corrosion products, etc.).

The risk of even a small leak from a tell-tale in some services may be considered unacceptable (e.g. in high-pressure systems, services containing H_2S/HF , or those that operate above the autoignition temperature). Piping with tell-tale holes may need its own inspection criteria (i.e. a more conservative retirement limit or t_{min} value to avoid a leak in a higher-risk system). Another key consideration when managing the risk of piping systems with tell-tale holes is identifying an appropriate response when a leak is discovered. Some sites allow the leaking holes to be “pinned” while in-service (this involves driving a tapered metal pin into the hole to stop the leak), and others have employed the use of nonengineered temporary clamps to stop the leak until a safe shutdown can be achieved. It is important to predetermine a response to a leaking tell-tale hole to minimize the risk potential.

10.7 Nonmetallic Piping

10.7.1 General

Nonmetallic piping systems are often used for fluids that are nontoxic, nonflammable, and environmentally benign. However, in some circumstances, even these piping systems are critical considering economic or operational consequences. Inspection intervals are best assessed using a risk-based approach. Factors that influence the initial inspection date are the amount and quality of the supervision and inspection performed during construction. The inspector should have adequate knowledge of FRP materials, resins, reinforcements, laminate imperfections, and manufacturing techniques.

Generally, experience shows an initial inspection should be performed within the first 2 years of operation. Subsequent intervals can be extended or reduced based on initial findings. A site experiencing a significant number of failures in the early years of operation may need to increase inspection activities and shorten intervals.

10.7.2 Initial Construction

Visual examination and pressure testing are the primary inspection and testing methods used during original construction. ASTM D2563 provides guidance for the visual examination of FRP components but is focused on manufacturing and assembly. Some of the more stringent specifications require RT and/or bond inspection tools of bonded nonmetallic joints. These are more advanced examinations to supplant the "coin tapping" method for locating delaminated or disbanded areas close to the surface of nonmetallic piping.

Nonmetallic joints should be examined during installation and upon completion. Bell-and-spigot and taper-taper joints should be inspected for proper specified gap and internally, when possible, for excess adhesive that can restrict the flow. The inspector should perform an external inspection to look for proper surface preparation, insertion, joint assembly, and alignment.

Butt-and-wrap joints should be inspected internally for the proper gap, cut edge protection, and the required paste to fill the gap. Externally, the joint should be checked for proper alignment, gap tolerance, thickness, width, laminate sequence, and taper. In addition, where pipe and fittings are joined, ensure that the fitting is properly tapered if thicker than the pipe.

Pressure testing at up to 1.5 times design pressure will reveal leaks from major flaws such as severe impact damage. Pressure tests, however, are not a guarantee of structural integrity. Joints with up to 85 % disbonding have reportedly passed pressure tests. The use of acoustic emission monitoring during pressure testing can identify material failure occurring prior to leakage, thereby increasing the sensitivity of the pressure test. This can be used in real time to prevent the pressure test from causing irreversible damage to the pipe that might otherwise occur without monitoring and lead to future in-service failure.

10.7.3 On-stream Examination and Testing Techniques

Many traditional NDE techniques and testing are used to assess nonmetallic piping. These techniques include the following:

- a) UT;
- b) RT;
- c) AE;
- d) hardness testing;
- e) thermographic imaging;
- f) MW.

See Table 6 for a comparison of those common nonmetallic piping NDE techniques.

11 Inspection Results

11.1 Evaluation of Inspection Results

Evaluating the results of the inspection and taking appropriate action based on that evaluation are necessary to gain the full benefit of any inspection. The purpose of the inspection is to determine the current condition and, when coupled with previous inspections, to determine the rate of damage. These data can then be used to estimate the remaining life of the asset, to determine if any corrective actions are required, and/or if adjustments need to be made to the current inspection plan or RBI assessment if applicable. Typical steps in the evaluation of inspection results may include, but are not limited to, the following:

- a) evaluate completeness and accuracy of the report to ensure that the inspection was executed per the inspection plan.

- b) review the inspection to determine if any relevant NDE indications are identified and ensure that they are properly sized.

Determine suitability for continued operation for the time frame as prescribed by the owner-operator based on the results of inspection conducted.

Table 6—Comparison of Common Nonmetallic Piping NDE Techniques

Technique	Advantages	Limitations
Ultrasonic	Can identify erosion damage and to some degree lack of adhesive in joints.	<p>UT of wall thickness requires special techniques and procedures to accommodate the unique characteristics of the nonmetallic materials construction.</p> <p>Probe selection, typically at the low-frequency range of 0.25 MHz to 2.25 MHz, is critical for ultrasonic attenuation characteristics as these vary with the construction and manufacturing processes.</p> <p>This technique cannot detect “kissing” bonds in thermal welds.</p> <p>The design and availability of suitable calibration samples are essential to successful examination.</p>
Radiography	<p>Can identify internal flaws of a volumetric nature and wall thickness variations.</p> <p>Can be used to verify joint gaps, offsets, etc.</p>	<p>Specific exposure techniques may need to be defined in procedures to obtain the best resolution as the lower atomic weight elements used in nonmetallic construction generally require lower exposure energy and times.</p> <p>Disbonding and lack of adhesion flaws may not be easily identifiable with this technique.</p> <p>Examination of nonmetallic piping has most of the typical limitations, such as personnel safety, fluid absorption, and flaw orientation.</p>
Acoustic emission	<p>A wide range of flaws can be detected.</p> <p>AE has been used on vessels and tanks constructed from FRP for many years and these procedures are encompassed in ASME <i>BPVC</i>, Section V, Article 11.</p> <p>Typical flaws identified include inadequate structural integrity due to weaknesses in design, production, or material damage, growth of delaminations, crack growth, fiber fracture and pull-out, inadequate curing, and physical leakage.</p> <p>Ability to characterize the cracking of fibers and delaminating of the matrix in real time.</p> <p>There is extensive successful reporting of the use of AE in relation to nonmetallic materials.</p>	<p>Some of the basic caveats related to AE still apply (e.g. the flaw must be active in emitting energy).</p> <p>A clear definition of the flaw is only possible with other complementary NDE techniques.</p>
Hardness	<p>Material property used to identify proper curing and long-term damage of the resin.</p> <p>The most common hardness reference is ASTM D2583.</p> <p>The Barcol hardness test method can be used to determine the hardness of both reinforced and nonreinforced rigid plastics.</p>	<p>Limited by available area (e.g. small-diameter bore pipe).</p> <p>Wax inhibition can yield lower hardness values.</p>

Table 6—Comparison of Common Nonmetallic Piping NDE Techniques *(continued)*

Thermography	Has been used to detect gross wall thickness changes due to erosion and lack of adhesive in bonded joints.	<p>Sensitive to surface or near-surface flaws.</p> <p>Does not reveal through-wall damage in thick wall piping.</p> <p>The limits of detection are relatively high with about a 0.25 in. difference in wall thickness and disbanded areas measuring 3 in. × 3 in.</p> <p>Detection is a function of thermal differentials. If the process stream is significantly different in temperature than the surrounding ambient temperature, then good profiles could be obtained.</p> <p>Alternate approaches are to introduce heat into the area of examination and monitor the rate of decay in relation to “good” samples.</p>
Microwave	<p>Gigahertz or terahertz microwave used to detect laminar non-fusion, “kissing” bonds, and impact damage.</p> <p>Has detected ingress of fluids into the substrate in woven materials.</p> <p>Technique has the ability to detect disbonding at a nonmetallic/metallic interface.</p>	Unable to inspect through any metallic cladding or coating.

11.2 Determination of Follow-up Actions

Taking the appropriate follow-up actions based on the evaluation of the inspection results is an important element of the mechanical integrity program. The appropriate follow up action for a given scenario is to be determined by the owner-operator. Several examples are listed below.

- a) When the remaining life is determined to be beyond the next planned inspection and/or planned outage, the inspection report is uploaded into the owner-operator system of record.
- b) When the remaining life is determined to be less than the next planned outage or next inspection window for equipment in-service, a repair recommendation, rerate, or combination of those should be initiated. This may include temporary repairs, a planned or unplanned outage for repair, additional inspections to monitor the damage, or other risk mitigation steps to ensure that the equipment is operated with sufficient safety margin. For example, a heavily corroded piping could have the deeper pits filled in by weld buildup and the piping could also be derated to account for the remaining pits that are not repaired.
- c) When the actual thickness is determined to be below the required thickness, a repair recommendation, rerate, or combination of those should be initiated. This may require temporary repairs, a planned or unplanned outage for repair, additional inspections to monitor the damage or other risk mitigation steps to ensure that the equipment is operated with sufficient safety margin.
- d) When equipment is out of service at the time of the inspection and the piping contains defects, the piping system is either repaired, rerated, or combination of those to a condition which extends the remaining life sufficiently to satisfy the owner-operator prior to returning to service.

11.3 Using Fitness-For-Service

When reviewing inspection reports, both corrosion-related and non-corrosion-related damage are often evaluated.

- a) For corrosion-related damage, the preliminary evaluation may be against simple screening criteria, such as comparing the wall loss to the design corrosion allowance. Piping systems may then be further evaluated using API 579-1/ASME FFS-1 to determine if the piping can remain in-service.
- b) For non-corrosion-related damage, API 579-1/ASME FFS-1 should be utilized.

Once the acceptable damage limits have been established, the rate of damage should be determined based on the equipment age, previous inspection reports, operating history, and other relevant information.

The current condition, rate of damage, and acceptable damage limits together are used to estimate the remaining service life of the equipment.

Some jurisdictions require the owner-operator to have an approved Fitness-For-Service program before API 579-1/ASME FFS-1 can be used.

12 Rerating and Repair

12.1 Rerating of Piping System

12.1.1 General

Rerating of a piping system is an acceptable method of addressing specific types of damage. Rerating the piping can decrease the required thickness, or it can increase the piping system's corrosion allowance. Operating pressures (including process upsets or multiple operating scenarios) should be reviewed to determine to what pressure the piping could potentially be rerated. For example, where an inspection has found evidence that thinning has occurred, a rerate may be completed to decrease the MAWP and/or allowable temperature, which may decrease the required thickness and, therefore, increase the corrosion allowance.

The relief valves associated with the rerate should be reviewed to ensure the settings agree with the new operating conditions. For example, the orifice size or valve may require changes to cover the new rerate conditions.

Piping may be rerated to decrease the required thickness and therefore increase the corrosion allowance for future metal loss. This would increase the remaining life of the piping and increase the next inspection interval.

12.1.2 Repairs and Alterations

Inspection of repairs and alterations to piping systems may involve several steps in the performance of the work to ensure that it complies with the applicable sections of API 570 and/or ASME PCC-2. The inspector should be involved in planning, execution, and documentation of repairs and alterations. The inspector may need to consult with a piping engineer and corrosion specialist to properly plan and execute the piping work.

Some typical inspection activities involved with planning repairs and alterations include the following.

- a) Providing necessary field data, such as piping diameter, measured wall thickness, and material of construction; the required data can vary depending on the work to be performed and whether it is a temporary repair, a permanent repair, or an alteration.
- b) Developing and/or reviewing the scope of work; supporting engineering design calculations should be available for review with the assurance that they apply to the piping system and work being performed. Additional requirements, such as PWHT, are defined for the work.

- 1) If any restorative changes result in a change of design temperature or pressure, the requirements for rerating also should be satisfied.
- 2) Any welding, cutting, or grinding operation on a pressure-containing piping component not specifically considered an alteration is considered a repair.
- c) Developing an inspection test plan for the work; the inspector should establish appropriate NDE hold points to be used during the execution of the work. The inspection test plan should include any testing requirements as well as evaluation requirements to be used upon execution and completion of the work.
- d) Reviewing and accepting any weld procedures to be used for the work; ASME *BPVC*, Section IX, should be referenced when reviewing weld procedures and applicable procedure qualification records. API 577 should be reviewed for details on weld techniques and weld procedures. API 582 provides additional guidance on welding requirements for the industry.
- e) Reviewing welder qualifications to verify that they are qualified for the welding procedures to be used for the work; ASME *BPVC*, Section IX, and API 577 should be reviewed for details on welder performance qualifications.
- f) Reviewing material test reports, as required, to ensure that all materials of construction are per the piping specification and/or scope of work.
- g) Reviewing applicable NDE procedures and NDE examiner qualifications/certifications; verify that the NDE procedures are appropriate for the work to be performed and examiners are qualified/certified to perform the examination technique.

During the execution of repairs, the inspector should ensure that the work is executed per the scope and meets code requirements. Typical inspector activities include the following:

- a) ensuring that NDE is performed at the hold points as stated in the inspection plan;
- b) reviewing examination results to ensure that they meet code and specification requirements;
- c) ensuring that any heat treatment is performed per the work scope;
- d) ensuring that testing requirements, such as hardness and pressure testing, are performed and acceptable.

Documentation of repairs and alterations can include the written scope of work, supporting engineering design calculations, NDE and test results, heat-treatment charts, material test reports, welding procedure specifications, and welding performance qualification records.

12.2 Repairing Pipe Damage

12.2.1 General Comments on Repairing Piping

When repairing a piping system:

- a) The codes and standards governing the piping system's design, construction, and inspection should be reviewed. The repairs should not violate requirements. Several jurisdictions recognize API 570 as the proper code for repairing or altering petroleum or chemical piping systems.
- b) The repairs should require inspection, examination, and/or testing to verify that they have been properly executed.

- c) Where jurisdictions do not regulate the repair and alteration of piping systems, the owner-operator should have as part of the mechanical integrity program a method under which repairs and alterations have been completed and documented.
- d) The defects requiring repair and the repair procedures employed should be recorded in the permanent records maintained for the piping system.

Refer to ASME PCC-2 for repair methods.

12.2.2 Pressure Boundary Repairs

Corrosion losses are the most common defect to repair. Multiple repair methods apply to corroded piping system areas. The type of repair utilized will depend upon the extent of corrosion found and on the material accessibility (the time it takes to receive needed materials).

Repairs should comply with API 570 and any jurisdictional requirements. API 570 and ASME PCC-2 provide detailed techniques that can be utilized for different repairs. Scattered pitting deeper than that corrosion allowance should be reviewed following guidelines set in API 579-1/ASME FFS-1 or repaired.

Cracks are also common defects requiring repair. Cracks can be just surface cracks were grinding out the crack would not exceed the corrosion allowance or the piping system's excess wall (greater than the calculated minimum thickness). An engineer should evaluate cracks deeper than the corrosion allowance. The same applies to repairs not made per API 579-1/ASME FFS-1, Part 9.

For repairs needing long lead items, temporary repairs can be utilized until repair materials arrive. The piping can be repaired as the items arrive or during the next turnaround.

The cause of the problem resulting in the need to repair should be determined. Treating the source of the damage will, in many cases, prevent future problems.

12.2.3 Repair Inspections

Refer to API 577 to guide fabrication and repair welding inspection of refinery and chemical plant equipment.

For pipe walls crack repairs:

- The cracks can be arc gouged from end to end. Care should be used in arc gouging, as heat may cause the crack to enlarge or lengthen.
- Cutting a groove from both sides of the plate may be expedient if a crack extends completely through the plate.
- The crack must be completely removed before welding begins. MT or PT techniques can ensure that the crack is removed. If one plate has several cracks, it may be wise to replace the entire plate.
- Check the repairs carefully. Examine the crack weld repair after the first weld pass to verify that the crack has not reappeared.

If the remaining metal, after flaw removal, provides adequate strength and corrosion protection, the repair may be completed without welding by tapering and blending the edges of the cavity.

Welding repairs should be inspected to verify the execution, completion, and acceptability of the repair. Normally, a visual examination is sufficient for most minor repairs. However, the appropriate NDE as specified in the approved repair plan or application code of construction should be used on major repairs

as approved by the owner-operator. Additionally, if required by the applicable construction code, RT or angle beam UT examination should also be performed.

Pipe sections may replace locally deteriorated areas. For insert patches, the patch's joint efficiency should be equal to or greater than the original pipe joints' efficiency.

Repairs of metallic linings require welding. PT or MT in addition to visual inspection of the repair welds after thorough slag removal is typically performed to check weld quality.

In accordance with API 570, a pressure test may be required after repairs or alterations have been completed. Alternatively, specific NDE approved by the owner-operator may be used in lieu of a pressurized test. API 570 and/or ASME PCC-2, Article 500, should be used to determine pressure test requirements.

13 Pressure Tests

13.1 Purpose of Testing

A pressure test conducted on in-service piping may function as a leak test, or if the pressure is high enough, it can reveal gross errors in design or fabrication. Pressure tests of existing piping should be performed in accordance with the requirements of API 570. Piping systems that may be subjected to pressure testing include the following:

- a) underground lines and other inaccessible piping;
- b) water and other nonhazardous utility lines;
- c) long oil-transfer lines in areas where a leak or spill would not be hazardous to personnel or harmful to the environment;
- d) complicated manifold systems;
- e) small piping and tubing systems;
- f) all systems, after a chemical cleaning operation;
- g) when required by the jurisdiction.

The reasons and procedures for pressure-testing piping are generally the same as those for equipment. When vessels of process units are pressure tested, the main lines connected to the vessels are often tested at the same time. Service testing of Category D piping systems is limited to the 150 psi (1034.2 kPa) design gauge pressure upper limit defined for Category D fluid service in ASME B31.3.

13.2 Types of Pressure Tests (Future Content)

13.3 Performing Pressure Tests

API 570—Section 5.11 provides guidelines for preparing piping for pressure testing, and ASME PCC-2, Article 501, offers useful guidance on performing pressure and tightness testing of piping systems.

During liquid pressure testing, all air should be expelled from the piping through vents provided at all high points. If the system is not full of liquid, the trapped air will compress. With large quantities of a compressible medium in the system, a failure will be more violent than in a liquid-full system because of expansion of the compressible medium.

Care should be taken to ensure that the test does not overpressure the system, including components (e.g. expansion joints) that may have a lower design pressure than the remainder of the piping system. Calibrated pressure gauges properly located and of the proper range should be used and carefully watched during pressuring. When all air is expelled from the system, the pressure will rise rapidly. A sudden rise in pressure can cause shock, resulting in failure of the tested equipment.

The pressure for a liquid pressure test is usually supplied by an available pump. If a pump of sufficient head is not available, the necessary test pressure can be supplied by bottled inert gas, such as nitrogen, bled in at the top of the system after the system is filled with the test liquid. This method has the disadvantage of introducing a compressible medium into the system, but the quantity can be kept small. In either case, if over pressuring can occur, a relief device should be installed to protect the system.

Various fluids can be used for pressure testing. The following are the most commonly used:

- a) water with or without an inhibitor, freezing-point depressant, or wetting agent;
- b) liquid products normally carried in the system, if they are not toxic or likely to cause a fire in case of a leak or failure;
- c) steam;
- d) air, carbon dioxide, nitrogen, helium, or another inert gas.

NOTE ASME B31.3 has restrictions on the use of the test mediums listed in item c) and item d).

If a leak or failure occurs, fluid may be released in the area of the piping being tested. For this reason, the fluid should not be harmful to adjoining equipment or to the plant sewer system, and appropriate safety precautions are taken to avoid personnel exposure.

Water may not be suitable as a test fluid in some piping systems, such as acid lines, cryogenic systems, and air-drier systems. Uninhibited salt water can cause corrosion of some nonferrous alloys and SCC of austenitic stainless steels. Salt water can also cause corrosion of ferritic steels and severe pitting of austenitic steels, such as valve trim or plating. Most natural waters contain bacteria that can lead to microbiologically induced corrosion if the water is left in the piping for too long after a pressure test. Austenitic stainless steels have failed after 2 to 5 weeks of this kind of exposure.

Water can freeze in cold weather unless a freezing-point depressant is used. The depressant should not be harmful to the sewer system or other place of disposal. Steam is sometimes used to warm the water and prevent freezing. The transition temperature of the steel should be considered to prevent brittle failure when the testing is during cold weather or with cold fluids.

A steam test may be advantageous where steam is used for heating or purging equipment before operation. The steam pressure should not exceed the operating pressure. An advantage of steam is that it heats the piping, thereby popping flux from welds in piping that could have passed a water test; however, steam testing does have several disadvantages. Condensation occurs, and the draining of condensate may be necessary before operations are started. When high-pressure steam is used, leaks are difficult to detect and can burn personnel who are around the equipment. Steam also has the previously mentioned disadvantage of compressible media. ASME B31.3 allows for a leakage test with the flowing medium at operating conditions for Category D fluid services [i.e. the fluid should be nonflammable, nontoxic, and 366 °F (186 °C) or lower].

NOTE If steam is used as the test medium for piping other than Category D piping, the rules for pneumatic testing stated in ASME B31.3 should be followed.

Pneumatic tests in conjunction with a soap solution, foaming agent, or sonic leak detector are sometimes permissible for small lines and systems. The preferred medium for pneumatic testing is an inert gas.

Compressed air should not be used where flammable fluids can be present. Leaks that would not be detected during a liquid pressure test can often be detected by a pneumatic test. Because nitrogen and helium are more penetrating than air, they are used when service conditions are particularly critical. Filling any piping system with an inert gas creates an asphyxiation hazard at every stage in the process. Precautions must be taken to ensure that no personnel are inadvertently exposed to a low-oxygen atmosphere.

Pneumatic testing should be conducted strictly in accordance with ASME B31.3. All the precautions specified in ASME B31.3 should be strictly observed, including the elimination of conditions under which brittle fracture might occur.

13.4 Pressure Testing Considerations (Future Content)

13.5 Pressure Test Safety Considerations

The stored energy associated with a pneumatic test is significantly greater than a hydrostatic test. It is important to understand there can be a high consequence associated with the sudden release of stored energy if a piping system fails during a pneumatic test. While performing hydrostatic or pneumatic pressure tests consider cordoning off the area. For safety, personnel should maintain the designated distance from the piping until the test is completed and pressure is released. ASME PCC-2, Article 501, contains guidelines for determining safe distance based on the calculated stored energy of the test. Owner-operators often require risk analysis and higher level of approvals for performing pneumatic tests.

Large diameter piping and its structural supports may not be designed to support the weight of the piping filled with water. Before a hydrostatic test is performed, the engineer should determine if the support structure is adequate for the weight. If the piping or its supports are inadequate for a hydrostatic test, a pneumatic test may be considered.

Blinds and/or blanks used for pressure testing should be of adequate thickness to withstand the pressure that will be applied during testing. If it is later determined that a pressure test is needed due to inspection findings or previously unplanned repairs, the blind or blanks need to be evaluated to determine if they are adequate for the testing pressure. If they are inadequate, blinds or blanks of an appropriate thickness and material should be installed in place of the isolation blinds to resist the pressure stresses of the test.

The number of inspection personnel in the area should be limited to the number necessary to run the test. When making pneumatic pressure tests, the recommendations set forth in the ASME *Code* should be followed.

14 Records and Reports

14.1 General

The necessity of keeping complete records in a detailed and orderly manner is an important responsibility of the inspector as well as a requirement of many regulations (e.g. OSHA 29 *CFR* 1910.119). Accurate records allow an evaluation of service life on any piping, valve, or fitting. From such records, a comprehensive picture of the general condition of any piping system can be determined. When properly organized, such records form a permanent record from which corrosion rates, inspection intervals and probable replacement or repair intervals can be determined. A computer program (e.g. IDMS) can be used to assist in a more complete evaluation of recorded information and to determine the next inspection date.

Inspection records should contain the following:

- a) original date of installation;
- b) specifications of the materials used;

- c) original thickness measurements (i.e. baseline measurements);
- d) locations and dates of all subsequent thickness measurements;
- e) calculated retirement thickness;
- f) repairs and replacements;
- g) temporary repairs;
- h) pertinent operational changes (i.e. change in service);
- i) Fitness-For-Service assessments;
- j) RBI assessments.

These and other pertinent data should be arranged on suitable forms so that successive inspection records will furnish a chronological picture. Each inspection group should develop appropriate inspection forms.

14.2 Records

14.2.1 Sketches

Isometric or oblique drawings provide a means of documenting the size and orientation of piping lines, the location and types of fittings, valves, orifices, etc., and the locations of CMLs. Although original construction drawings can be used, normally separate sketches are made by, or for, the inspection department. Figure 34 is a typical isometric sketch for recording field data.

Sketches have the following functions:

- a) identify particular piping systems and circuits in terms of location, size, material specification, general process flow, and service conditions;
- b) show points to be opened for visual inspection and parts that require replacement or repair;
- c) serve as field data sheets on which can be recorded the locations of thickness measurements, corrosion findings, and sections requiring replacement; these data can be transferred to continuous records at a later date;
- d) assist at future inspections in determining locations that require examination;
- e) identification of temporary repairs (e.g. clamps, wraps).

Sketches may also contain the following:

- a) pipe schedule;
- b) location of piping supports;
- c) location of SAI;
- d) P&ID number.

Refer to 7.3.3 for additional guidance on isometric drawings and their content.

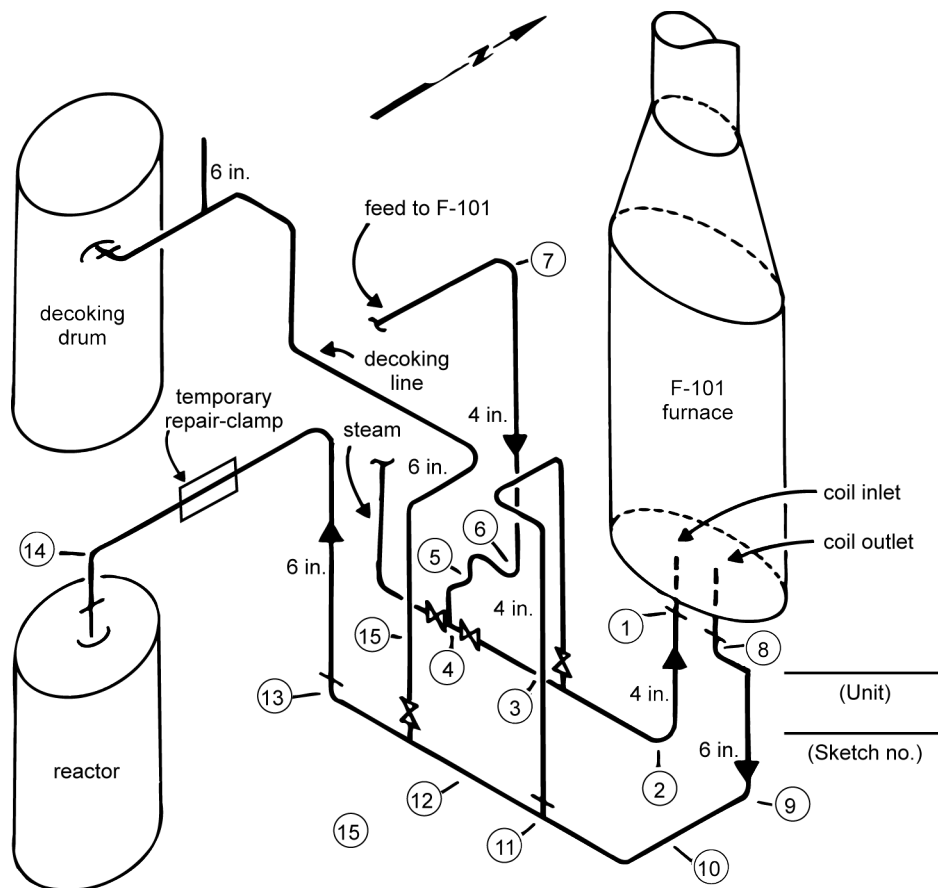

NOTE Circled numbers indicate points at which thickness should be monitored by the inspector when the thickness datasheet is filled out.

Figure 34—Typical Isometric Sketch

14.2.2 Numbering Systems

Typically, a coding system is used to uniquely identify the process unit, the piping system, the circuit, and the CMLs.

14.2.3 Thickness Data

A record of thickness data obtained during periodic or scheduled inspections provides a means of arriving at corrosion or erosion rates and expected material life. Some companies use computerized record systems (e.g. IDMS) for this purpose. The data can be shown on sketches or presented as tabulated information attached to the sketches. Figure 35 shows one method of tabulating thickness readings and other information.

14.2.4 Review of Records

Records of previous inspections and inspections conducted during the current operating period should be reviewed soon after the inspections are conducted to schedule the next inspection date. This review should provide lists of areas that are approaching retirement thickness, areas that have previously shown high corrosion rates, and areas in which current inspection has indicated a need for further investigation. From these lists, a work schedule should be prepared for additional on-stream inspection, if possible, and for

inspections to be conducted during the next shutdown period. Such a schedule will assist in determining the number of inspectors to be assigned to the work.

In addition, from the review of the records of previous inspections, a list should be made of all expected repairs and replacements. This list should be submitted to the maintenance department far enough in advance of the shutdown to permit any required material to be obtained or, if necessary, fabricated. This list will also assist the maintenance personnel in determining the number of personnel required during the shutdown period.

14.2.5 Record Updates

Records should be updated following inspection activities within a reasonable amount of time affording the inspector enough time to properly gather, analyze, and record data. Many sites have internal requirements indicating a maximum duration between obtaining data and updating records. These requirements generally allow records to be updated within a few weeks of completing the inspection activities. Establishing a time frame for record updates helps ensure that data and information are accurately recorded and do not become lost and details forgotten.

14.2.6 Audit of Records

Inspection records should be regularly audited against code requirements, the site's quality assurance inspection manual, and site procedures. The audit should assess whether the records meet those requirements and whether the records are of appropriate quality/accuracy. Regular audits provide a means to identify gaps and deficiencies in existing inspection programs and define corrective actions, such as focused training.

14.3 Reports (Future Content)

Identification Number								<input type="checkbox"/> Piping		<input type="checkbox"/> Vessel													
								Description _____															
Inspection Interval				Design Conditions				Operating Conditions								Remaining Life (Years/Months) _____							
Internal		External		Temperature		Pressure		Temperature		Pressure		Material		Set by Last Reading at Point No. _____									
								Next Recommended Inspection Date _____															
								Initial Reading				Subsequent Reading				Subsequent Reading							
Point	Reading Location			Size	Limit	Thickness	Method	Month	Year	Inspection Temperature	Thickness	Method	Month	Year	Inspection Temperature	Thickness	Method	Month	Year	Inspection Temperature			
Inspector _____										Inspector _____					Inspector _____								

NOTE The "Method" column should be used to indicate the method used to measure the thickness (e.g. N = nominal; U = ultrasonic; X = radiography; and C = calipers).

Figure 35—Typical Tabulation of Thickness Data

Annex A (informative)

External Inspection Checklist for Process Piping

Piping circuit #:

Date inspected:

Item inspected by status:

a) Leaks:

- 1) process;
- 2) steam tracing;
- 3) existing clamps.

b) Misalignment:

- 1) piping misalignment/restricted movement;
- 2) expansion joint misalignment.

c) Vibration:

- 1) excessive overhung weight;
- 2) inadequate support;
- 3) thin, small-bore, or alloy piping;
- 4) threaded connections;
- 5) loose supports causing metal wear.

d) Supports:

- 1) shoes off support;
- 2) hanger distortion or breakage;
- 3) bottomed-out springs;
- 4) brace distortion/breakage;
- 5) loose brackets;
- 6) slide plates/rollers;
- 7) counterbalance condition.

Annex B (informative)

Tables of Pipe Schedules

Table B.1—Nominal Pipe Sizes, Schedules, Weight Classes, and Dimensions of Ferritic Steel Pipe

Pipe Size		Actual OD in.	Actual OD mm	Schedule	Weight Class	Approximate ID in.	Approximate ID mm	Nominal Thickness in.	Nominal Thickness mm
NPS	DN								
1/8	6	0.405	10.3	40	STD	0.269	6.84	0.068	1.73
				80	XS	0.215	5.48	0.095	2.41
1/4	8	0.540	13.7	40	STD	0.364	9.22	0.088	2.24
				80	XS	0.302	7.66	0.119	3.02
3/8	10	0.675	17.1	40	STD	0.493	12.48	0.091	2.31
				80	XS	0.423	10.7	0.126	3.20
1/2	15	0.840	21.3	40	STD	0.622	15.76	0.109	2.77
				80	XS	0.546	13.84	0.147	3.73
				160		0.464	11.74	0.188	4.78
				—	XXS	0.252	6.36	0.294	7.47
3/4	20	1.050	26.7	40	STD	0.824	20.96	0.113	2.87
				80	XS	0.742	18.88	0.154	3.91
				160		0.612	15.58	0.219	5.56
				—	XXS	0.434	11.06	0.308	7.82
1	25	1.315	33.4	40	STD	1.049	26.64	0.133	3.38
				80	XS	0.957	24.3	0.179	4.55
				160		0.815	20.7	0.250	6.35
				—	XXS	0.599	15.22	0.358	9.09
1 1/4	32	1.660	42.2	40	STD	1.380	35.08	0.140	3.56
				80	XS	1.278	32.5	0.191	4.85
				160		1.160	29.5	0.250	6.35
				—	XXS	0.896	22.8	0.382	9.70
1 1/2	40	1.900	48.3	40	STD	1.610	40.94	0.145	3.68
				80	XS	1.500	38.14	0.200	5.08
				160		1.338	34.02	0.281	7.14
				—	XXS	1.100	28	0.400	10.15
2	50	2.375	60.3	40	STD	2.067	52.48	0.154	3.91
				80	XS	1.939	49.22	0.218	5.54
				160		1.687	42.82	0.344	8.74
				—	XXS	1.503	38.16	0.436	11.07
2 1/2	65	2.875	73.0	40	STD	2.469	62.68	0.203	5.16
				80	XS	2.323	58.98	0.276	7.01
				160		2.125	53.94	0.375	9.53
				—	XXS	1.771	44.96	0.552	14.02
3	80	3.500	88.9	40	STD	3.068	77.92	0.216	5.49
				80	XS	2.900	73.66	0.300	7.62
				160		2.624	66.64	0.438	11.13
				—	XXS	2.300	58.42	0.600	15.24
3 1/2	90	4.000	101.6	40	STD	3.548	90.12	0.226	5.74
				80	XS	3.364	85.44	0.318	8.08

Table B.1—Nominal Pipe Sizes, Schedules, Weight Classes, and Dimensions of Ferritic Steel Pipe
(continued)

Pipe Size		Actual OD in.	Actual OD mm	Schedule	Weight Class	Approximate ID in.	Approximate ID mm	Nominal Thickness in.	Nominal Thickness mm
NPS	DN								
4	100	4.500	114.3	40	STD	4.026	102.26	0.237	6.02
				80	XS	3.826	97.18	0.337	8.56
				120		3.624	92.04	0.438	11.13
				160		3.438	87.32	0.531	13.49
				—	XXS	3.152	80.06	0.674	17.12
5	125	5.563	141.3	40	STD	5.047	128.2	0.258	6.55
				80	XS	4.813	122.24	0.375	9.53
				120		4.563	115.9	0.500	12.70
				160		4.313	109.54	0.625	15.88
				—	XXS	4.063	103.2	0.750	19.05
6	150	6.625	168.3	40	STD	6.065	154.08	0.280	7.11
				80	XS	5.761	146.36	0.432	10.97
				120		5.501	139.76	0.562	14.27
				160		5.187	131.78	0.719	18.26
				—	XXS	4.897	124.4	0.864	21.95
8	200	8.625	219.1	20		8.125	206.4	0.250	6.35
				30		8.071	205.02	0.277	7.04
				40	STD	7.981	202.74	0.322	8.18
				60		7.813	198.48	0.406	10.31
				80	XS	7.625	193.7	0.500	12.70
				100		7.437	188.92	0.594	15.09
				120		7.187	182.58	0.719	18.26
				140		7.001	177.86	0.812	20.62
				—	XXS	6.875	174.64	0.875	22.23
10	250	10.75	273.0	20		10.250	260.3	0.250	6.35
				30		10.136	257.4	0.307	7.80
				40	STD	10.020	254.46	0.365	9.27
				60	XS	9.750	247.6	0.500	12.70
				80		9.562	242.82	0.594	15.09
				100		9.312	236.48	0.719	18.26
				120		9.062	230.12	0.844	21.44
				140		8.750	222.2	1.000	25.40
				160		8.500	215.84	1.125	28.58

Table B.1—Nominal Pipe Sizes, Schedules, Weight Classes, and Dimensions of Ferritic Steel Pipe
(continued)

Pipe Size		Actual OD in.	Actual OD mm	Schedule	Weight Class	Approximate ID in.	Approximate ID mm	Nominal Thickness in.	Nominal Thickness mm
NPS	DN								
12	300	12.750	323.8	20	STD	12.250	311.1	0.250	6.35
				30		12.090	307.04	0.330	8.38
				—		12.000	304.74	0.375	9.53
				40		11.938	303.18	0.406	10.31
				—	XS	11.750	298.4	0.500	12.70
				60		11.626	295.26	0.562	14.27
				80		11.374	288.84	0.688	17.48
				100		11.062	280.92	0.844	21.44
				120		10.750	273	1.000	25.40
				140		10.500	266.64	1.125	28.58
160	10.126	257.16	1.312	33.32					
14	350	14.000	355.6	10	STD	13.500	342.9	0.250	6.35
				20		13.376	339.76	0.312	7.92
				30		13.250	336.54	0.375	9.53
				40		13.124	333.34	0.438	11.13
				—	XS	13.000	330.2	0.500	12.70
				60		12.812	325.42	0.594	15.09
				80		12.500	317.5	0.750	19.05
				100		12.124	307.94	0.938	23.83
				120		11.812	300.02	1.094	27.79
				140		11.500	292.088	1.125	31.756
160	11.188	284.18	1.406	35.71					
16	400	16.000	406.4	10	STD	15.500	393.7	0.250	6.35
				20		15.376	390.56	0.312	7.92
				30		15.250	387.34	0.375	9.53
				40		15.000	381	0.500	12.70
				60	XS	14.688	373.08	0.656	16.66
				80		14.312	363.52	0.844	21.44
				100		13.938	354.02	1.0311	26.19
				120		13.562	344.48	1.219	30.96
				140		13.124	333.34	1.438	36.53
				160		12.812	325.42	1.594	40.49
18	450	18.000	457	10	STD	17.500	444.3	0.250	6.35
				20		17.376	441.16	0.312	7.92
				—		17.250	437.94	0.375	9.53
				30		17.124	434.74	0.438	11.13
				—	XS	17.000	431.6	0.500	12.70
				40		16.876	428.46	0.562	14.27
				60		16.500	418.9	0.750	19.05
				80		16.124	409.34	0.938	23.83
				100		15.688	398.28	1.156	29.36
				120		15.250	387.14	1.375	34.93
140	14.876	377.66	1.562	39.67					
160	14.438	366.52	1.781	45.24					

Table B.1—Nominal Pipe Sizes, Schedules, Weight Classes, and Dimensions of Ferritic Steel Pipe
(continued)

Pipe Size		Actual OD in.	Actual OD mm	Schedule	Weight Class	Approximate ID in.	Approximate ID mm	Nominal Thickness in.	Nominal Thickness mm
NPS	DN								
20	500	20.000	508	10	STD XS	19.500	495.3	0.250	6.35
				20		19.250	488.94	0.375	9.53
				30		19.000	482.6	0.500	12.70
				40		18.812	477.82	0.594	15.09
				60		18.376	466.76	0.812	20.62
				80		17.938	455.62	1.031	26.19
				100		17.438	442.92	1.281	32.54
				120		17.000	431.8	1.500	38.10
				140		16.500	419.1	1.750	44.45
				160		16.062	407.98	1.969	50.01
22	550	22.000	559	10	STD XS	21.500	546.3	0.250	6.35
				20		21.250	539.94	0.375	9.53
				30		21.000	533.6	0.500	12.70
				60		20.250	514.54	0.875	22.23
				80		19.750	501.84	1.125	28.58
				100		19.250	489.14	1.375	34.93
				120		18.750	476.44	1.625	41.28
				140		18.250	463.74	1.875	47.63
				160		17.750	451.04	2.125	53.98
				24		600	24.000	610	10
20	23.250	590.94	0.375		9.53				
—	23.000	584.6	0.500		12.70				
30	22.876	581.46	0.562		14.27				
40	22.624	575.04	0.688		17.48				
60	22.062	560.78	0.969		24.61				
80	21.562	548.08	1.219		30.96				
100	20.938	532.22	1.531		38.89				
120	20.376	517.96	1.812		46.02				
140	19.876	505.26	2.062		52.37				
160	19.312	490.92	2.344	59.54					

Table B.2—Nominal Pipe Sizes, Schedules, and Dimensions of Stainless Steel Pipe

Pipe Size		Actual OD in.	Actual OD mm	Schedule	Wall Thickness in.	Wall Thickness mm
NPS	DN					
1/8	6	0.405	10.3	10S	0.049	1.24
				40S	0.068	1.73
				80S	0.096	2.41
1/4	8	0.540	13.7	10S	0.065	1.65
				40S	0.088	2.24
				80S	0.119	3.02
3/8	10	0.675	17.1	10S	0.065	1.65
				40S	0.091	2.31
				80S	0.126	3.20
1/2	15	0.840	21.3	5S	0.065	1.65
				10S	0.083	2.11
				40S	0.109	2.77
				80S	0.147	3.73
3/4	20	1.050	26.7	5S	0.065	1.65
				10S	0.083	2.11
				40S	0.113	2.87
				80S	0.154	3.91
1	25	1.315	33.4	5S	0.065	1.65
				10S	0.109	2.77
				40S	0.133	3.38
				80S	0.179	4.55
1 1/4	32	1.660	42.2	5S	0.065	1.65
				10S	0.109	2.77
				40S	0.140	3.56
				80S	0.191	4.85
1 1/2	40	1.900	48.3	5S	0.065	1.65
				10S	0.109	2.77
				40S	0.145	3.68
				80S	0.200	5.08
2	50	2.375	60.3	5S	0.065	1.65
				10S	0.109	2.77
				40S	0.154	3.91
				80S	0.218	5.54
2 1/2	65	2.875	73	5S	0.083	2.11
				10S	0.120	3.05
				40S	0.203	5.16
				80S	0.276	7.01
3	80	3.500	88.9	5S	0.083	2.11
				10S	0.120	3.05
				40S	0.216	5.49
				80S	0.300	7.62

Table B.2—Nominal Pipe Sizes, Schedules, and Dimensions of Stainless Steel Pipe (continued)

Pipe Size		Actual OD in.	Actual OD mm	Schedule	Wall Thickness in.	Wall Thickness mm
NPS	DN					
3½	90	4.000	101.6	5S	0.083	2.11
				10S	0.120	3.05
				40S	0.226	5.74
				80S	0.318	8.08
4	100	4.500	114.3	5S	0.083	2.11
				10S	0.120	3.05
				40S	0.237	6.02
				80S	0.337	8.56
5	125	5.563	141.3	5S	0.109	2.77
				10S	0.134	3.40
				40S	0.258	6.55
				80S	0.375	9.53
6	150	6.625	168.3	5S	0.109	2.77
				10S	0.134	3.40
				40S	0.280	7.11
				80S	0.432	10.97
8	200	8.625	219.1	5S	0.109	2.77
				10S	0.148	3.76
				40S	0.322	8.18
				80S	0.500	12.70
10	250	10.750	273.1	5S	0.134	3.40
				10S	0.165	4.19
				40S	0.365	9.27
				80S	0.500	12.70
12	300	12.750	323.9	5S	0.156	3.96
				10S	0.180	4.57
				40S	0.375	9.53
				80S	0.500	12.70
14	350	14.00	355.6	5S	0.156	3.96
				10S	0.188	4.78
16	400	16.00	406.4	5S	0.165	4.19
				10S	0.188	4.78
18	450	18.00	457	5S	0.165	4.19
				10S	0.188	4.78
20	500	20.00	508	5S	0.188	4.78
				10S	0.218	5.54
22	550	22.00	559	5S	0.188	4.78
				10S	0.218	5.54
24	600	24.00	610	5S	0.218	5.54
				10S	0.250	6.35

Table B.3—Permissible Tolerances in Diameter and Thickness for Ferritic Pipe

ASTM Material Standard	Acceptable Diameter Tolerances ^a			Acceptable Thickness Tolerances ^b
A53	≤ NPS 1½	+1/64 in. (0.4 mm)	-1/64 in. (0.4 mm)	-12.5 %
	> NPS 1½	±1 %		
A106 A312/A312M A530/A530M A790/A790M	≥ NPS 1/8 ≤ NPS 1½	+1/64 in. (0.4 mm)	-1/64 in. (0.4 mm)	
	> NPS 1½ ≤ NPS 4	+1/32 in. (0.79 mm)	-1/32 in. (0.79 mm)	
	> NPS 4 ≤ NPS 8	+1/16 in. (1.59 mm)	-1/32 in. (0.79 mm)	
	> NPS 8 ≤ NPS 18	+3/32 in. (2.38 mm)	-1/32 in. (0.79 mm)	
	> NPS 18 ≤ NPS 26	+1/8 in. (3.18 mm)	-1/32 in. (0.79 mm)	
	> NPS 26 ≤ NPS 34	+5/32 in. (3.97 mm)	-1/32 in. (0.79 mm)	
> NPS 34 ≤ NPS 48	+3/16 in. (4.76 mm)	-1/32 in. (0.79 mm)		
A134	Circumference ±0.5 % of specified diameter			
A135/A135M	+1 % of nominal			-12.5 %
A358/A358M	±0.5 %			-0.01 in. (0.3 mm)
A409/A409M	Wall < 0.188 in. (4.8 mm) thickness ±0.20 %			-0.018 in. (0.46 mm)
	Wall ≥ 0.188 in. (4.8 mm) thickness ±0.40 %			
A451/A451M	—			+1/8 in. (3 mm); -0
A524	> NPS 1/8 ≤ 1½	+1/64 in. (0.4 mm)	-1/32 in. (0.8 mm)	-12.5 %
	> NPS 1½ ≤ 4	+1/32 in. (0.8 mm)	-1/32 in. (0.8 mm)	
	> NPS 4 ≤ 8	+1/16 in. (1.6 mm)	-1/32 in. (0.8 mm)	
	> NPS 8 ≤ 18	+3/32 in. (2.4 mm)	-1/32 in. (0.8 mm)	
	> NPS 18	+1/8 in. (3.2 mm)	-1/32 in. (0.8 mm)	
A587	See ASTM A587, Table 4			
A660/A660M	—			10 % greater than the specified minimum wall thickness
	—			Zero less than the specified minimum wall thickness
A671/A671M	+0.5 % of specified diameter			0.01 in. (0.3 mm) less than the specified thickness
A672/A672M, A691/A691M	+0.5 % of specified diameter			0.01 in. (0.3 mm) less than the specified thickness
A813/A813M	≥ NPS 1¼	±0.010 in. (0.25 mm)		±12 % for wall thickness < 0.188 in. (4.8 mm) ±0.030 in. (0.8 mm) for wall thickness ≥ 0.188 in. (4.8 mm)
	≥ NPS 1½ ≤ NPS 6	±0.020 in. (0.5 mm)		
	≥ NPS 8 ≤ NPS 18	±0.030 in. (0.75 mm)		
	≥ NPS 20 ≤ NPS 24	±0.040 in. (1 mm)		
	NPS 30	±0.050 in. (1.25 mm)		
A814/A814M	See ASTM A814/A814M, Table 1			
^a Tolerance on DN unless otherwise specified.				
^b Tolerance on nominal wall thickness unless otherwise specified.				

Annex C (informative)

Statistical Analysis of Circuit Thickness Data

Many statistical tools can be employed once piping circuits have been properly established. While such calculations offer a convenient means to numerically summarize circuit data, it is often the combination of descriptive statistics plus data visualization through statistical plots that provide the most useful results. The results of statistical analysis of the CML data using descriptive statistics and statistical plots should be evaluated for validity and interpreted by a person who is deemed competent by the owner-operator.

Probability plots are convenient tools for modeling circuit thickness or corrosion rate data. Many differing statistical programs can be utilized to visualize large quantities of data and obtain the parameters of interest. Generally, simple two-parameter distributions such as normal, log-normal, and Weibull are good candidates to describe thickness and corrosion rate trends. In many cases, the “goodness of fit” to a particular distribution can be visually assessed from a probability plot, although many statistical packages also provide goodness-of-fit statistics. Any significant deviation from the best-fit line may be an indication of localized corrosion and/or data anomalies to be investigated.

Graphical visualization tools may be used in addition to descriptive statistics to demonstrate the validity of the statistical modeling assumptions and the goodness-of-fit of the data, especially in the range of highest interest from an integrity point of view. Examples include the use of normal probability or extreme value distribution plots to indicate the goodness-of-fit for the largest or smallest values in a data set of interest. Visualization of all data on an appropriately selected scale may reveal a lack of goodness-of-fit or correlations that are not readily apparent from descriptive statistics.

While the following discussion focuses on the use of probability plots, similar results may be obtained without plotting software. Descriptive statistics may be generated in spreadsheets that estimate distribution parameters, calculate projected values, and provide other useful circuit analysis information. If calculations are performed without the aid of data visualization, some assessment as to the goodness-of-fit and the presence of outliers would provide additional data.

When utilizing any statistical analysis or best fit of corrosion data, it is important to understand the credible damage mechanisms on the individual piping circuit. The data itself may appear normal due to the CMLs inspected; however, areas of higher damage were missed. A thorough review of other data (e.g. operating conditions) is also needed to increase the accuracy of any statistical model being utilized.

Typical circuit analysis applications include the following.

- 1) Creating separate plots for long-term and short-term corrosion rates to determine if the rate distributions are significantly different.

A shift in the distribution’s location parameter (e.g. the mean, for normal distribution) may indicate higher or lower rates, while changes in the shape parameter (e.g. the standard deviation) suggest a change in the degree of localized corrosion. This type of analysis can be useful for assessing feedstock and other process changes that may have occurred over a period of time. Due to the impact of thickness measurement accuracies and the physical nature of corrosion phenomena, special care should be taken when comparing data sets over different time intervals. A direct comparison of a 1-year interval to a 5-year interval data may be misleading for the following two reasons.

- The time scale of corrosion physics dictates decreasing correlation between measurements as the time lag between successive measurements increases. Therefore, short-term and long-term variability usually have different scatter.
- Measurement uncertainty tends to affect the results as well. If the measurements are significantly impacted by measurement errors, the scatter would follow a square root relationship with time.

2) Screening the circuit corrosion rate and thickness data for uniform versus localized trends.

When plotting thicknesses or corrosion rates, the best-fitting distribution type, as well as trends in the parameters, can be used to screen for localized corrosion. Parameter trends may additionally reveal important changes over time, relating to higher corrosion rates and/or localized corrosion tendencies. For example, corrosion rate distributions for uniform services tend to follow a normal distribution. Significantly nonuniform/localized services (e.g. ammonium bisulfide or naphthenic acid corrosion) will typically fit best to a log-normal distribution with a wide shape parameter. On thickness plots, reductions in the scale parameter are related to the corrosion rate, whereas wider shape parameters suggest more localized behavior.

3) Estimating a representative corrosion rate for a piping circuit.

Once a corrosion rate plot has been prepared (considering both long-term and short-term rates), a representative rate may be assigned for the entire piping circuit. The owner-operator may establish guidelines based (for example) on service class or risk, utilizing a specific occurrence level rate, in remaining life calculations. For uniform services, a mean rate might be appropriate, whereas localized corrosion services may require a higher probability. If an additional factor of safety is needed, confidence intervals may be added to the plot and a specified occurrence level at the upper confidence interval could be used.

4) Evaluating the circuit design to confirm the assumption of similar damage mechanisms and corrosion rates within a circuit.

If all corrosion rates in a circuit do not demonstrate a satisfactory fit as defined by the owner-operator, consider grouping the data based on knowledge of the piping design, assigned damage mechanisms, and pertinent process conditions. This type of grouping is generally required when subpopulations may be present. For example, a plot of all circuit corrosion data may not exhibit satisfactory goodness-of-fit. It may be subsequently observed that higher rates tend to be associated with elbow fittings (or even more specifically, the extrados of those fittings). This would suggest that elbow (or extrados) readings be plotted separately. If the resulting plots demonstrate a significantly improved goodness-of-fit, the circuit design may be validated, but the assigned damage mechanisms may require review. This type of feedback often provides considerable insight into the inspection program.

A nongraphical method for identifying potential subpopulations is to calculate the covariance. For example, a covariance exceeding 10 % could suggest the presence of subpopulations, requiring the data to be grouped, as outlined above.

5) Identifying data outliers and other anomalies.

Sometimes, the data that does not fit the model is of the most interest. Elevated corrosion rates or low thicknesses that appear as outliers (e.g. points lying outside the plot confidence intervals) should not be discarded unless a specific cause can be assigned. Each such outlier should be carefully reviewed to confidently rule out the possibility of localized corrosion. In some cases, this may require obtaining confirmation readings.

6) Estimating the thickness at a low occurrence level, or the probability of the minimum required thickness for a particular size/component within a circuit.

Thickness probability plots may be used to estimate the minimum thickness at a selected low occurrence level for size/component combinations in a circuit. Alternatively, the probability of reaching the minimum required thickness may be estimated, essentially yielding a probability of retirement that may be used in risk-based programs. Suitable data validation to identify replacement sections or potential schedule changes would typically accompany this type of analysis.

Because of thickness measurement uncertainty, the scatter in the corrosion rate distribution can be overestimated. Any thickness measurement uncertainty effects should be estimated, with adequate corrections made, to minimize the impact on probability estimates. Otherwise, some overconservatism may be expected in the results.

7) Assessing the standard error of the data.

It is often useful to gain an understanding of how “good” a representative corrosion rate or minimum thickness estimate may be. It may also be of interest to estimate how much data should be taken for subsequent inspections. Such estimates can be made by exploring different confidence intervals on the probability plot. Current and future inspections can be modeled to estimate the effects of additional (or less) data. The owner-operator may choose to adopt practices using variable confidence intervals depending on service class or risk to estimate minimum data requirements. Such techniques may also be used to quantify representative sampling requirements.

Bibliography

- [1] API Specification 5L, *Line Pipe*
- [2] API Standard 530, *Calculation of Heater-tube Thickness in Petroleum Refineries*
- [3] API Recommended Practice 577, *Welding Processes, Inspection, and Metallurgy*
- [4] API Recommended Practice 581, *Risk-Based Inspection Methodology*
- [5] API Recommended Practice 582, *Welding Guidelines for the Chemical, Oil, and Gas Industries*
- [6] API Recommended Practice 583, *Corrosion Under Insulation and Fireproofing*
- [7] API Recommended Practice 584, *Integrity Operating Windows*
- [8] API Bulletin 590, *SCIMI Term, Definition, and Acronym Standardization Work Process*
- [9] API Standard 594, *Check Valves: Flanged, Lug, Wafer, and Butt-welding*
- [10] API Standard 598, *Valve Inspection and Testing*
- [11] API Standard 599, *Metal Plug Valves—Flanged, Threaded, and Welding Ends*
- [12] API Standard 600, *Steel Gate Valves—Flanged and Butt-welding Ends, Bolted Bonnets*
- [13] API Standard 602, *Gate, Globe, and Check Valves for Sizes DN 100 (NPS 4) and Smaller for the Petroleum and Natural Gas Industries*
- [14] API Standard 603, *Corrosion-resistant, Bolted Bonnet Gate Valves—Flanged and Butt-welding Ends*
- [15] API Standard 607, *Fire Test for Quarter-turn Valves and Valves Equipped with Nonmetallic Seats*
- [16] API Standard 608, *Metal Ball Valves—Flanged, Threaded and Welding Ends*
- [17] API Standard 609, *Butterfly Valves: Double-flanged, Lug- and Wafer-type, and Butt-welding Ends*
- [18] API Recommended Practice 615, *Valve Selection Guide*
- [19] API Recommended Practice 621, *Reconditioning of Metallic Gate, Globe, and Check Valves*
- [20] API Recommended Practice 751, *Safe Operation of Hydrofluoric Acid Alkylation Units*
- [21] API Recommended Practice 932-B, *Design, Materials, Fabrication, Operation, and Inspection Guidelines for Corrosion Control in Hydroprocessing Reactor Effluent Air Cooler (REAC) Systems*
- [22] API Standard 936, *Refractory Installation Quality Control—Inspection and Testing Monolithic Refractory Linings and Materials*
- [23] API Recommended Practice 939-C, *Guidelines for Avoiding Sulfidation (Sulfidic) Corrosion Failures in Oil Refineries*
- [24] API Recommended Practice 941, *Steels for Hydrogen Service at Elevated Temperatures and Pressures in Petroleum Refineries and Petrochemical Plants*

- [25] API Recommended Practice 945, *Avoiding Environmental Cracking in Amine Units*
- [26] API Recommended Practice 970, *Corrosion Control Document Systems*
- [27] API Recommended Practice 2001, *Fire Protection in Refineries*
- [28] API Publication 2217A, *Safe Work in Inert Confined Spaces in the Petroleum and Petrochemical Industries*
- [29] ASME B1.20.1, *Pipe Threads, General Purpose (Inch)*
- [30] ASME B16.5, *Pipe Flanges and Flanged Fittings: NPS 1/2 Through NPS 24 Metric/Inch Standard*
- [31] ASME B16.47, *Large Diameter Steel Flanges: NPS 26 Through NPS 60 Metric/Inch Standard*
- [32] ASME B31.1, *Power Piping*
- [33] ASME B31G, *Manual for Determining the Remaining Strength of Corroded Pipelines*
- [34] ASME B36.10M, *Welded and Seamless Wrought Steel Pipe*
- [35] ASME B36.19, *Welded and Seamless Wrought Stainless Steel Pipe*
- [36] ASME Boiler and Pressure Vessel Code (BPVC), *Section V: Nondestructive Examination, Article 11: Acoustic Emission Examination of Fiber Reinforced Plastic Vessels*
- [37] ASME PCC-1, *Pressure Boundary Bolted Flange Joint Assembly*
- [38] ASME PCC-2, *Repair of Pressure Equipment and Piping*
- [39] ASME PCC-3, *Inspection Planning Using Risk-Based Methods*
- [40] ASME RTP-1, *Reinforced Thermoset Plastic Corrosion-Resistant Equipment*
- [41] ASNT Recommended Practice SNT-TC-1A³, *Personnel Qualification and Certification in Nondestructive Testing*
- [42] ASTM A53/A53M, *Standard Specification for Pipe, Steel, Black and Hot-Dipped, Zinc-Coated, Welded and Seamless*
- [43] ASTM A106, *Standard Specification for Seamless Carbon Steel Pipe for High-Temperature Service*
- [44] ASTM A134/A134M, *Standard Specification for Pipe, Steel, Electric-Fusion (Arc)-Welded (Sizes NPS 16 and Over)*
- [45] ASTM A135/A135M, *Standard Specification for Electric-Resistance-Welded Steel Pipe*
- [46] ASTM A312/A312M, *Standard Specification for Seamless, Welded, and Heavily Cold Worked Austenitic Stainless Steel Pipes*

³ American Society for Nondestructive Testing, 1201 Dublin Road, Suite #G04, Columbus, Ohio 43215, www.asnt.org.

- [47] ASTM A358/A358M, *Standard Specification for Electric-Fusion-Welded Austenitic Chromium-Nickel Stainless Steel Pipe for High-Temperature Service and General Applications*
- [48] ASTM A409/A409M, *Standard Specification for Welded Large Diameter Austenitic Steel Pipe for Corrosive or High-Temperature Service*
- [49] ASTM A451/A451M, *Standard Specification for Centrifugally Cast Austenitic Steel Pipe for High-Temperature Service*
- [50] ASTM A524, *Standard Specification for Seamless Carbon Steel Pipe for Atmospheric and Lower Temperatures*
- [51] ASTM A530/A530M, *Standard Specification for General Requirements for Specialized Carbon and Alloy Steel Pipe*
- [52] ASTM A587, *Standard Specification for Electric-Resistance-Welded Low-Carbon Steel Pipe for the Chemical Industry*
- [53] ASTM A660/A660M, *Standard Specification for Centrifugally Cast Carbon Steel Pipe for High-Temperature Service*
- [54] ASTM A671/A671M, *Standard Specification for Electric-Fusion-Welded Steel Pipe for Atmospheric and Lower Temperatures*
- [55] ASTM A672/A672M, *Standard Specification for Electric-Fusion-Welded Steel Pipe for High-Pressure Service at Moderate Temperatures*
- [56] ASTM A691/A691M, *Standard Specification for Carbon and Alloy Steel Pipe, Electric-Fusion-Welded for High-Pressure Service at High Temperatures*
- [57] ASTM A790/A790M, *Standard Specification for Seamless and Welded Ferritic/Austenitic Stainless Steel Pipe*
- [58] ASTM A813/A813M, *Standard Specification for Single- or Double-Welded Austenitic Stainless Steel Pipe*
- [59] ASTM A814/A814M, *Standard Specification for Cold-Worked Welded Austenitic Stainless Steel Pipe*
- [60] ASTM B88, *Standard Specification for Seamless Copper Water Tube*
- [61] ASTM D2563, *Standard Practice for Classifying Visual Defects in Glass-Reinforced Plastic Laminate Parts*
- [62] ASTM D2583, *Standard Test Method for Indentation Hardness of Rigid Plastics by Means of a Barcol Impressor (Withdrawn)*
- [63] ASTM E1118/ASTM E1118M, *Standard Practice for Acoustic Emission Examination of Reinforced Thermosetting Resin Pipe (RTRP)*
- [64] MTI Project 129-99 ⁴, *Self-help Guide for In-service Inspection of FRP Equipment and Piping*

⁴ Materials Technology Institute, 1001 Craig Road, Suite 490, St. Louis, Missouri 63146, www.mti-global.org.

- [65] MTI Project 160-04, *Guide for Design, Manufacture, Installation & Operation of FRP Flanges and Gaskets*
- [66] NACE SP0169⁵, *Control of External Corrosion on Underground or Submerged Metallic Piping Systems*
- [67] NACE SP0198, *Control of Corrosion Under Thermal Insulation and Fireproofing Materials—A Systems Approach*
- [68] NACE SP0274, *High-Voltage Electrical Inspection of Pipeline Coatings*
- [69] NACE SP0114, *Refinery Injection and Process Mix Points*
- [70] NFPA 704⁶, *Identification of the Fire Hazards of Materials for Emergency Response*
- [71] OLF 055⁷, *Recommended Guidelines for NDT of GRP Pipe Systems and Tanks*
- [72] 29 *Code of Federal Regulations (CFR) 1910.119*⁸, *Process Safety Management of Highly Hazardous Chemicals—Compliance Guidelines and Enforcement Procedures*

⁵ NACE International (now Association for Materials Protection and Performance), 15835 Park Ten Place, Houston, Texas 77084, www.ampp.org.

⁶ National Fire Protection Association, 1 Batterymarch Park, Quincy, Massachusetts, 02169, www.nfpa.org.

⁷ Offshore Norge (Norwegian Oil and Gas Association), Fjordpiren, Laberget 22, 4020 Stavanger, Norway, <https://offshorenorge.no>.

⁸ Occupational Safety and Health Administration, 200 Constitution Avenue, NW, Washington, DC 20210. The *Code of Federal Regulations* is available from the U.S. Government Printing Office, <http://bookstore.gpo.gov>.



200 Massachusetts Avenue, NW
Suite 1100
Washington, DC 20001-5571
USA

202-682-8000

Phone Orders: 1-800-854-7179 (Toll-free in the U.S. and Canada)
303-397-7956 (Local and International)

Fax Orders: 303-397-2740

Information about API publications, programs and services is available
on the web at www.api.org.

Product No. C57405